



AquaSense®

ZEMS G2 Series

Automatic Systems Sensor-Operated
Flushometer

Installation, Operation, Maintenance
and Parts Manual



Sensor-Operated Exposed Systems

ZEMS6000AV	ZEMS6200AV-3
ZEMS6200AV	ZEMS6001AV
ZEMS6000AV-2	ZEMS6201AV
ZEMS6200AV-2	ZEMS6003AV
ZEMS6000AV-3	ZEMS6203AV

Sensor-Operated Concealed Systems

ZEMS6140AV	ZEMS6190AV
ZEMS6240AV	ZEMS6290AV
ZEMS6152AV	ZEMS6195AV
ZEMS6252AV	ZEMS6295AV
ZEMS6153AV	ZEMS6197AV
ZEMS6253AV	ZEMS6297AV

⚠ **WARNING:** Cancer and Reproductive Harm - www.P65Warnings.ca.gov

⚠ **ADVERTENCIA:** Cáncer y daño reproductivo - www.P65Warnings.ca.gov

⚠ **AVERTISSEMENT:** Cancer et effets néfastes sur la reproduction - www.P65Warnings.ca.gov

LIMITED WARRANTY

All goods sold hereunder are warranted to be free from defects in material and factory workmanship for a period of five years from the date of purchase. Decorative finishes warranted for one year. We will replace at no costs goods that prove defective provided we are notified in writing of such defect and the goods are returned to us prepaid at Sanford, NC, with evidence that they have been properly maintained and used in accordance with instructions. We shall not be responsible for any labor charges or any loss, injury or damages whatsoever, including incidental or consequential damages. The sole and exclusive remedy shall be limited to the replacement of the defective goods. Before installation and use, the purchaser shall determine the suitability of the product for his intended use and the purchaser assumes all risk and liability whatever in connection therewith. Where permitted by law, the implied warranty of merchantability is expressly excluded. If the products sold hereunder are "consumer products," the implied warranty of merchantability is limited to a period of three years and shall be limited solely to the replacement of the defective goods. All weights stated in our catalogs and lists are approximate and are not guaranteed.

Valve Rough-In

Models
ZEMS6000 and ZEMS6200

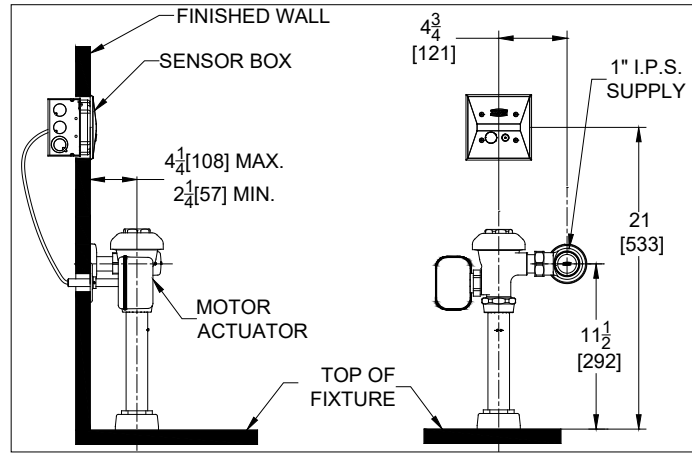

Models
ZEMS6000-2, ZEMS6000-3
ZEMS6200-2, ZEMS6200-3

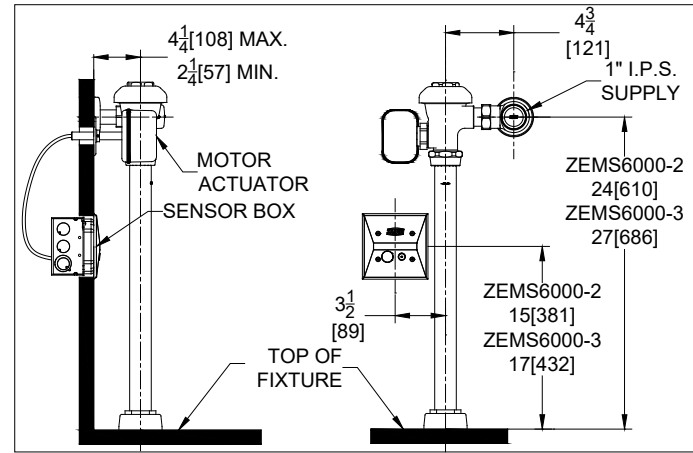

Valve Rough-In (Continued)

Models
ZEMS6190 and ZEMS6290

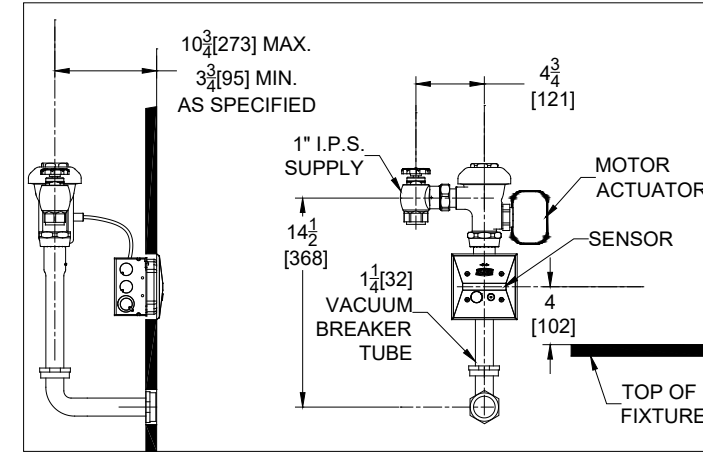

Models
ZEMS6195 and ZEMS6295

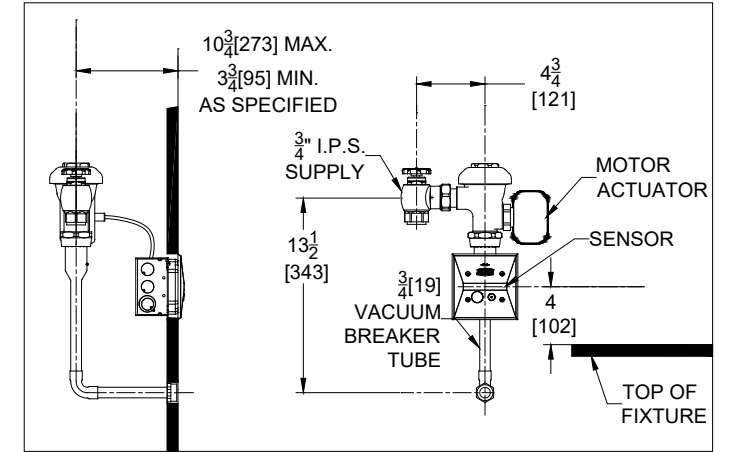

Models
ZEMS6140 and ZEMS6240

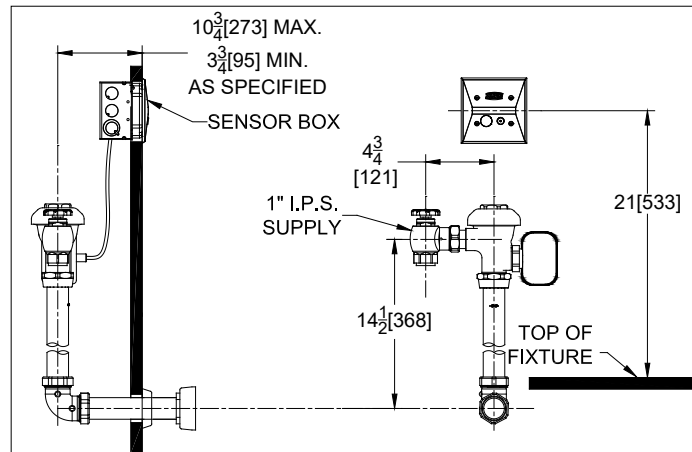

Models
ZEMS6152 and ZEMS6252

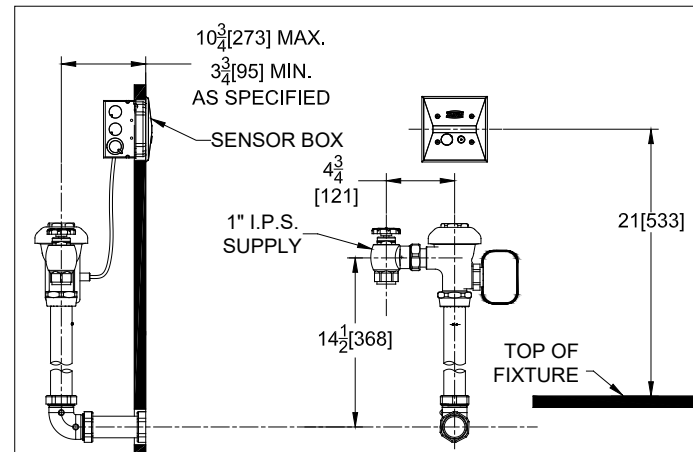

Models
ZEMS6153 and ZEMS6253

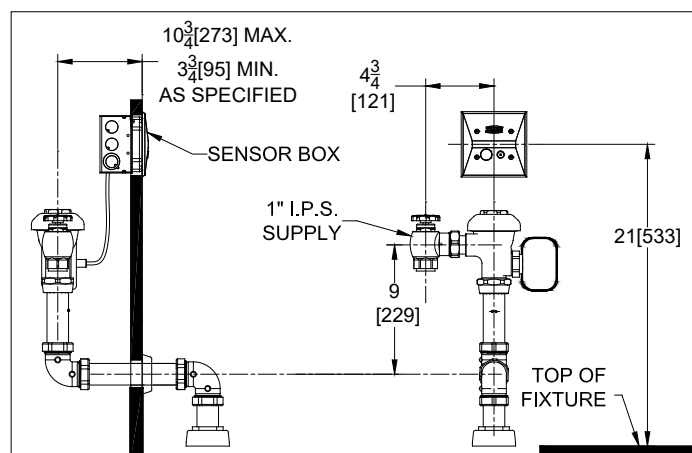

Models
ZEMS6001, ZEMS6003
ZEMS6201, ZEMS6203

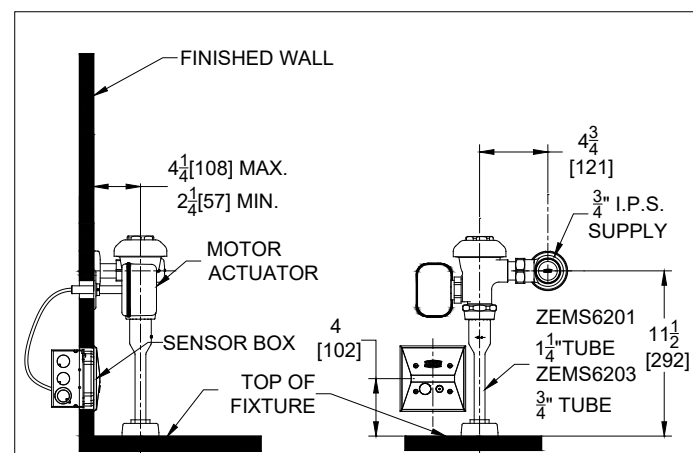

Models
ZEMS6197 and ZEMS6297

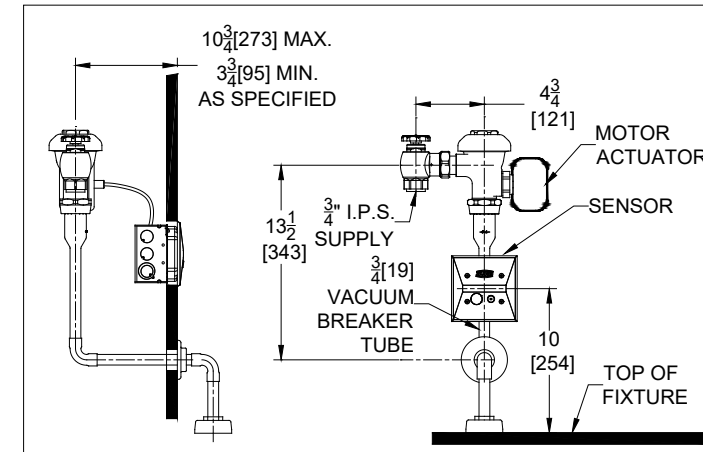

Prior to Installation

- Prior to installing the Zurn Automatic Sensor-equipped Flushometer, install the items listed below as illustrated in Figures 1 through 3.
- 2-gang electrical box (4 x 4 x 2 1/8, use Steel City #52171-N box, and #52-C-18 device cover or equivalent for sensor with closet or urinal installs);
 - Optional: Single-gang electrical outlet for plug-in power converter.
 - Electrical wiring to the power converter outlet (120 VAC, 35 watts service required for each power converter used).
 - Closet fixture.
 - Zurn carrier system, Z1200 series or equal.

Important:

- **ALL ELECTRICAL WIRING IS TO BE INSTALLED IN ACCORDANCE WITH NATIONAL/LOCAL CODES AND REGULATIONS.**
- **ALL PLUMBING IS TO BE INSTALLED IN ACCORDANCE WITH APPLICABLE CODES AND REGULATIONS.**
- **WATER SUPPLY LINES MUST BE SIZED TO PROVIDE AN ADEQUATE VOLUME OF WATER FOR EACH FIXTURE.**
- **FLUSH ALL WATER LINES PRIOR TO MAKING CONNECTIONS.**
- **SENSOR UNITS SHOULD NOT BE LOCATED ACROSS FROM EACH OTHER OR IN CLOSE PROXIMITY TO HIGHLY REFLECTIVE SURFACES.**
- **CONTROL STOP SHOULD NEVER BE OPENED TO ALLOW FLOW GREATER THAN FIXTURE IS CAPABLE OF EVACUATING. IN THE EVENT OF VALVE FAILURE, FIXTURE MUST BE ABLE TO HANDLE A CONTINUOUS FLOW.**

NOTES:
FOR INSTALLATIONS WITH GRAB BAR, CENTERLINE OF 4 X 4 BOX MUST BE A MINIMUM OF 4 INCHES ABOVE CENTERLINE OF GRAB BAR.

Electrical

AC/DC Power Supply

Install hardwired power supply (P6000-HW6) or receptacle for the Zurn Power Converter (P6900-ACA-BA) in a convenient location. An optional mini junction box (P6000-MJ) is recommended to distribute power to each sensor location.

NOTE: One Zurn P6000-HW6 can operate up to eight automatic sensor equipped flushometers, and the optional P6000-ACA-BA Power Converter can handle up to six flushometers and is supplied with a six-foot cord. If additional wire is needed from the Power Converter to the Flushometer(s), use #18 AWG (not provided). **Do not supply power** to the Power Converter until installation of actuator, sensor and Flushometer is completed and checked. **Proper polarity must be observed or damage to one or all components will result.**

Electrical Hook-up (Figure 1)

Be certain power is off to prevent damage to electrical components. Connect the sensor to the actuator and power converter exactly as shown in Figure 1.

Double check that power converter polarity is correct.

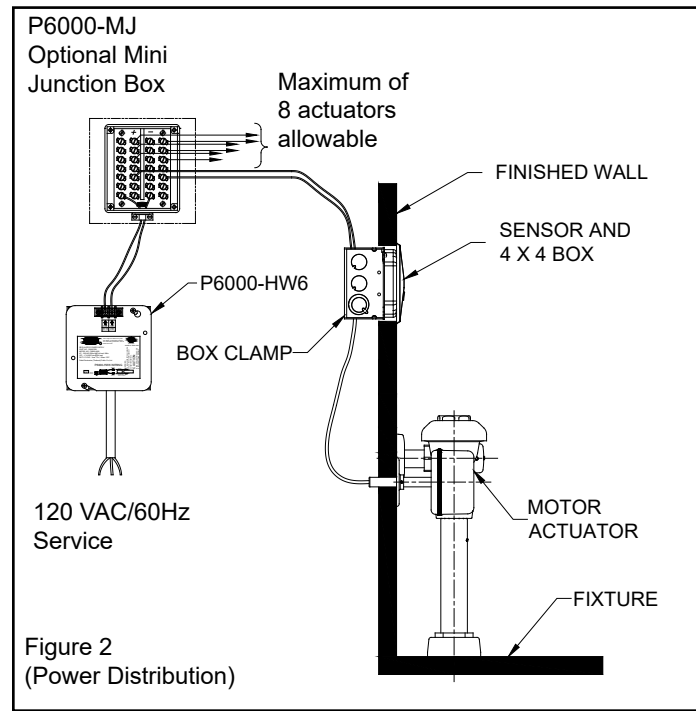
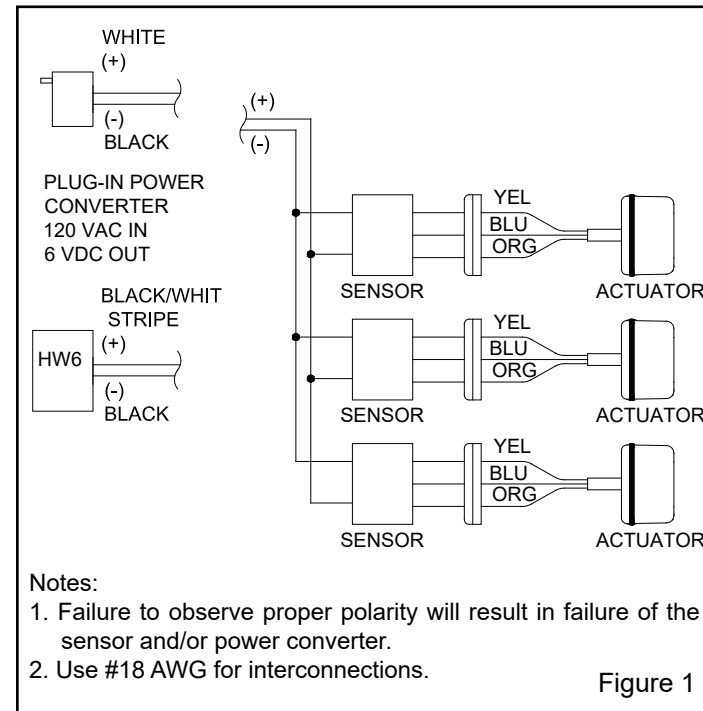

Sensor Installation

STEP 1 – Locate Sensor Box

Locate sensor box in the wall according to model number as shown on pages 2 and 3. Install plaster ring so screw holes are on left and right side of box (as shown in Figure 3). Trim tiles to allow screw holes in plaster ring to show.

Note: Product is configured at time of shipment for a 168 hour trap seal flush (SW1 in OFF position on rear of sensor). If a 48 hour trap seal flush is desired, set SW1 to ON position. (Figure 3A)

STEP 2 – Mount Automatic Sensor (Figure 3)

Install the Zurn Automatic Sensor into the lower half of the 2-gang electrical box using two (2) screws provided. Connect the 2-wire power cable and 3-wire actuator cable to sensor. Connectors are keyed to insure correct polarity. Ensure that the sensor is mounted in the orientation shown (with lens angled downward, see Figure 4).

STEP 3 – Install Top Bracket (Figure 3)

Fasten the Top Bracket to the electrical box using (2) screws provided. Ensure that bracket is mounted in the orientation shown (with face angled upward, see Figure 4).

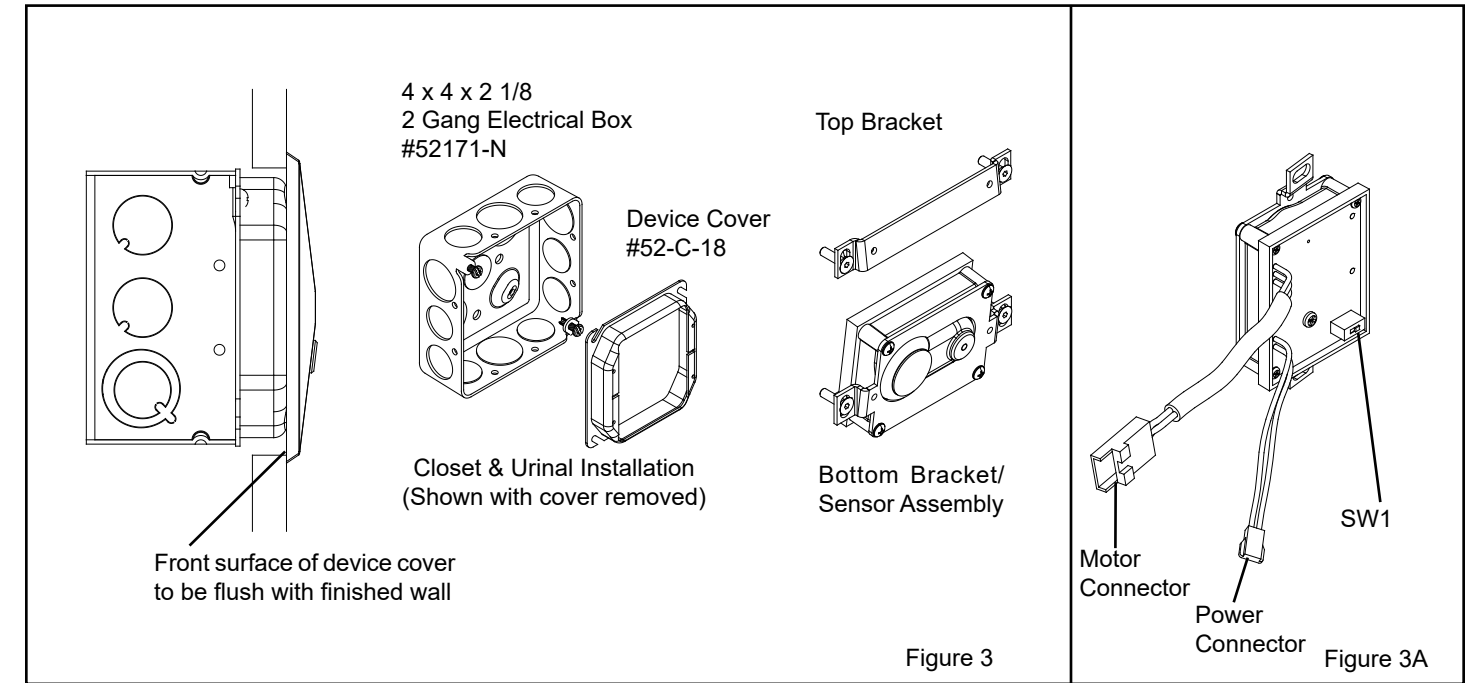

STEP 4 – Install Cover Plate (Figure 4)

Perform a trial fit of the Cover Plate and adjust positions of the sensor and top bracket as needed to ensure alignment of sensor lens, button, and cover screws. Fasten Cover Plate with (4) screws provided.

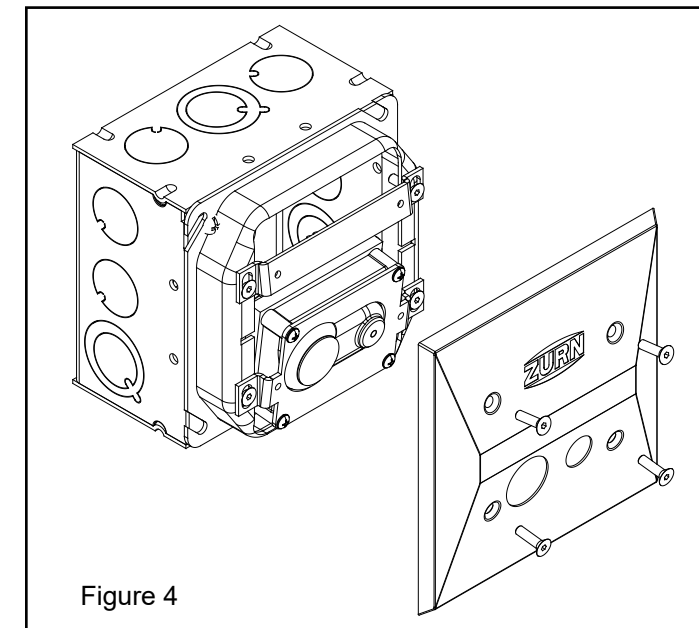

Mechanical

The AquaVantage® design is optimized to operate between 25 and 80 psi (172 to 552 kPa) of water pressure (running). The minimum pressure required for the valve to work properly is determined by the fixture selected. Please consult fixture manufacturer for water pressure requirements. Protect the chrome or special finish of this flushometer during installation. **Do not use toothed tools to install or service the valve as this will damage the finish.** Also, see "Care and Cleaning" section of this manual.

Control Stop Installation Instructions

STEP 1

Install control stop assembly by threading it onto water supply pipe and tightening with a smooth jawed wrench. Apply thread sealing compound or pipe tape to male NPT thread on sweat solder adapter only. See Figure 5.

Prior to turning on main water supply line ensure all stop valves are closed off tight by using a flathead screwdriver and turning the stop valve adjustment screw clockwise.

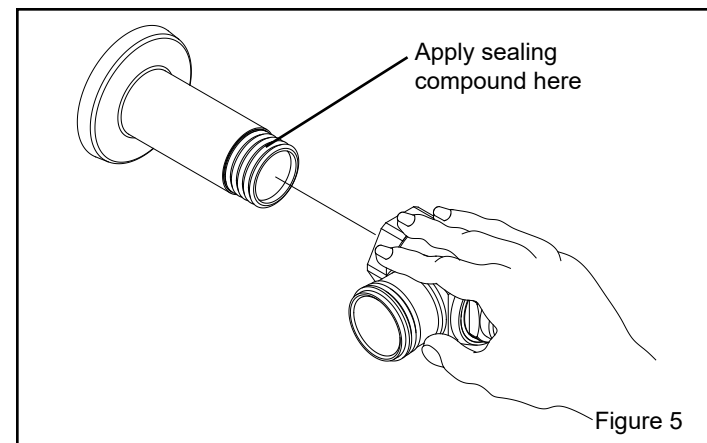

STEP 2

When all stop valves are properly connected to the water supply line and water pressure is available open the control stop using a flathead screwdriver and turning the stop valve adjustment screw counter clockwise. See Figure 6.

Allow the water supply line to flush any debris or sediment that may be present in the line.

Close the control stop once the lines are completely flushed.

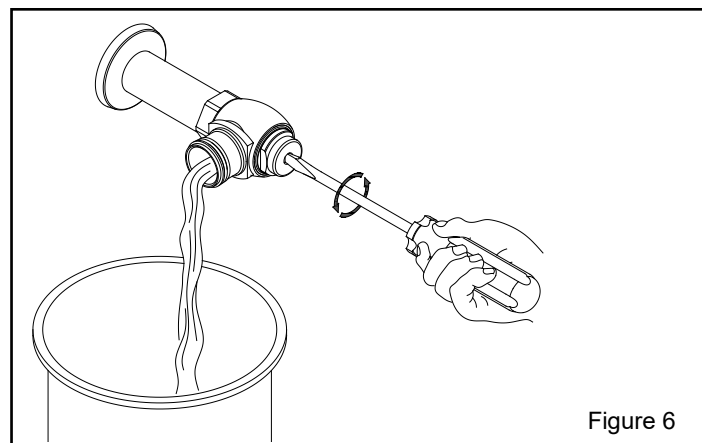

Flush Valve Installation

Prior to attaching flush valve to control inspect and verify that the O-ring seal is located within the O-ring groove at the tailpiece. Ensure the locking nut and locking snap ring are also present on the tailpiece. See Figure 7. Lubricate O-ring with water if necessary and insert flush valve tailpiece into the control stop valve. Tighten locking nut using a smooth jawed wrench.

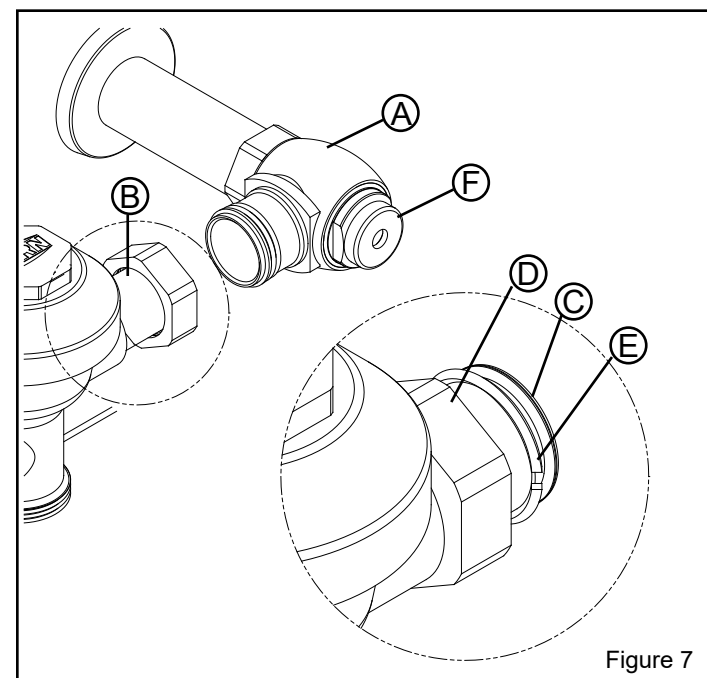

Install Vacuum Breaker Connection

Models ZEMS6000, ZEMS6000-2, ZEMS6000-3, ZEMS6001, ZEMS6003, ZEMS6200, ZEMS6200-2, ZEMS6200-3, ZEMS6201, and ZEMS6203

Slide the tube nut (H), spud nut (G), slip gasket, rubber gasket and spud escutcheon over the vacuum breaker tube and insert tube into fixture spud. Hand tighten tube nut to valve body and hand tighten spud nut onto fixture spud. Adjust the valve assembly for plumb. Tighten fixture spud nut (G), vacuum breaker tube nut (H) and lock nut (D) (fig. 7 & 8) with a wrench.

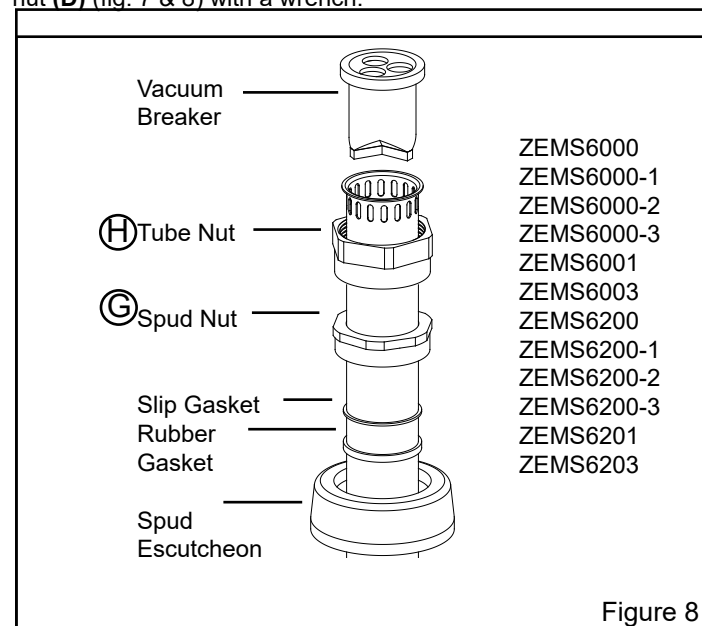

Install Vacuum Breaker Flush Connection

Models ZEMS6140, ZEMS6152, ZEMS6153, ZEMS6190, ZEMS6195, ZEMS6197, ZEMS6240, ZEMS6252, ZEMS6253, ZEMS6290, ZEMS6295 and ZEMS6297 (Figure 9)

NOTE: When cutting scored pipe, leave a minimum of 1-1/4" of scoring to ensure engagement with compression coupling. Assemble pipe, elbows, couplings, slip washers, rubber gaskets and flanges as illustrated in Figure 9. Hand tighten all couplings. Once installation is completed, tighten all connections.

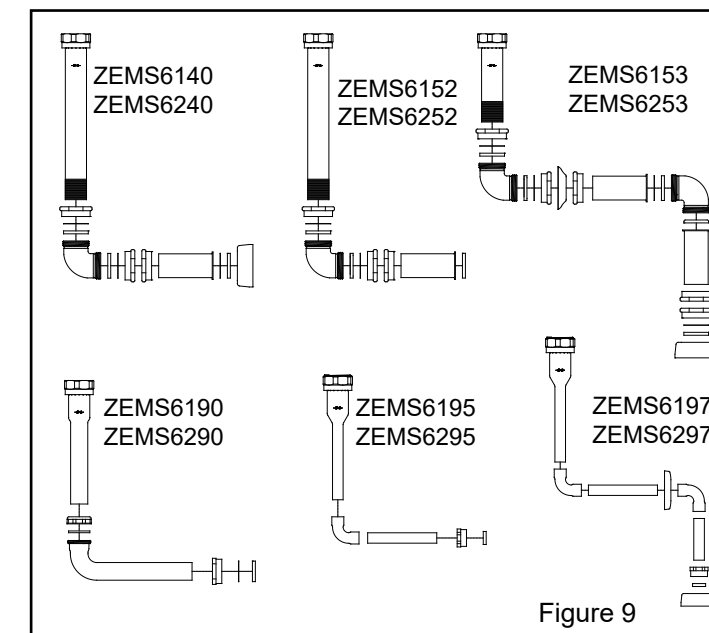

Concealed Flush Tube Installation Procedure

NOTE: These are for 1 1/2" flush connections.

When cutting scored pipe, leave a minimum of 1-3/4" (32mm) of scoring to ensure engagement with compression coupling. Clean and dry the plumbing to prepare for adhesive. Apply an 1/8" wide bead of the adhesive all around (Fig 2) the scoring between the gasket and the end of both tubes. Assemble elbow to tubes by pushing and rotating to spread adhesive.

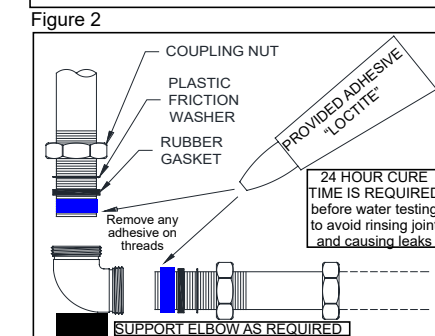
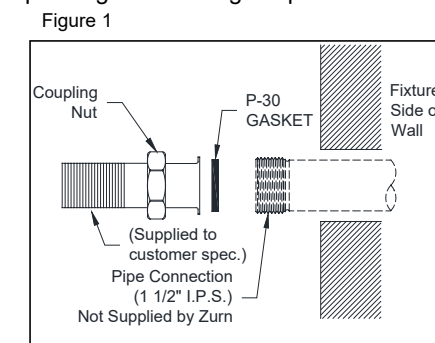

Recommendations:
DO NOT use any other pipe sealant or lubrication on these points.

The adhesive has a limited (2 minute) working time so tighten the connections immediately.

Do NOT run water through the pipes for at least 24 hours so the adhesive can set properly.

Support Elbow as required.

Motor Actuator Installation

1. Drill 1-3/4" diameter hole per Figures 10 or 11.
2. Run "fish tape" from electrical box to 1-3/4" hole.
3. Install actuator escutcheon to the actuator pipe with setscrew toward actuator. Do not tighten setscrew at this time.
4. Pull actuator cable through hole with fish tape and back to sensor box. Secure cable to box with box clamp.
5. With escutcheon loose and handle port washer installed, push cable into wall. The actuator must be angled away from the valve body at this time until the actuator push rod clears the handle port flange. The actuator can now be mounted to the flush valve and tightened.
6. Push escutcheon back to wall and tighten setscrew.

NOTE: See Figure 2 for typical installation including optional mini junction box.

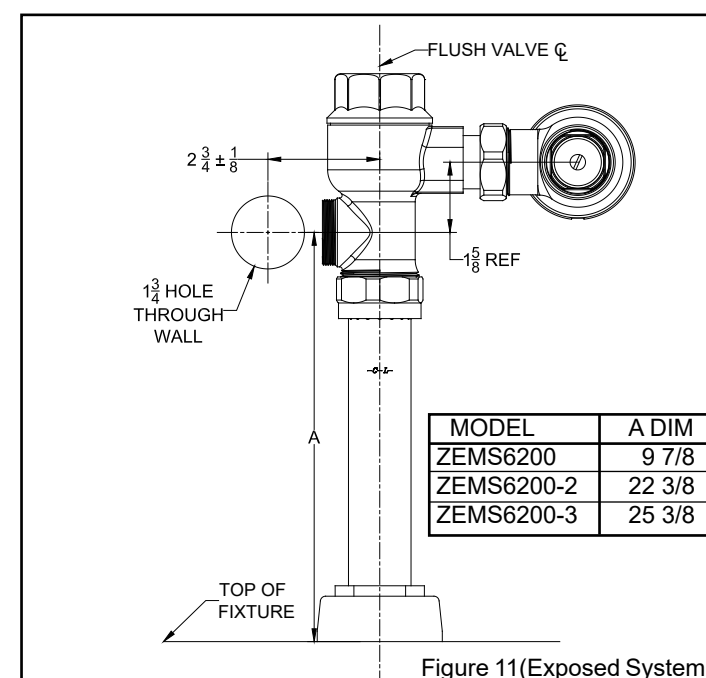
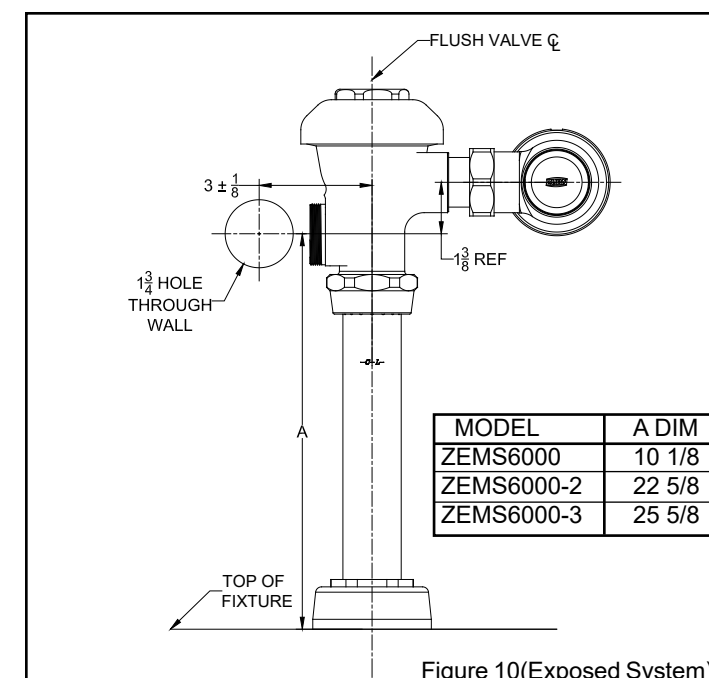

Customized Sensor Range Setting

The ZEMS is factory set to accommodate most closet and urinal installations. If this factory setting does not accommodate your specific environment, follow steps below to customize your range settings for your specific ZEMS model.

CALIBRATION INSTRUCTIONS FOR ZEMS G2

1. Obtain a target. SEE FIGURE 12.
2. PRESS and HOLD button for 10 seconds or until the LED turns solid.
(*Unit will blink four times and flush once while button is being held)
3. RELEASE finger after LED turns solid.
4. PRESS and HOLD button when LED starts blinking.
5. RELEASE finger when LED turns solid.
6. Set target at desired distance, (No less than 16") from sensor face and verify NO other objects are in view of sensor face.
7. Keep target steady - Unit will blink while calibrating.
8. After 30 seconds, calibration ends with a fast double blink or a solid LED for 5 seconds.
9. IF THE LED REMAINS SOLID FOR 5 SECONDS AFTER CALIBRATION, the calibration was NOT successful. REPEAT STEPS 2-8
10. For closet installations continue to "VERIFY CALIBRATION FOR CLOSET INSTALLATIONS".

Verify Calibration for Closet Installations

1. Stand outside closet stall and close door and verify that sensor does not see stall door. If LED blink/flashes, recalibrate to a shorter range.
2. Slowly open door to closet stall while looking at ZEMS-IS sensor.
3. If led blinks while door is opening, recalibrate to a shorter range. FAILURE TO DO SO WILL RESULT IN GHOST FLUSHING.

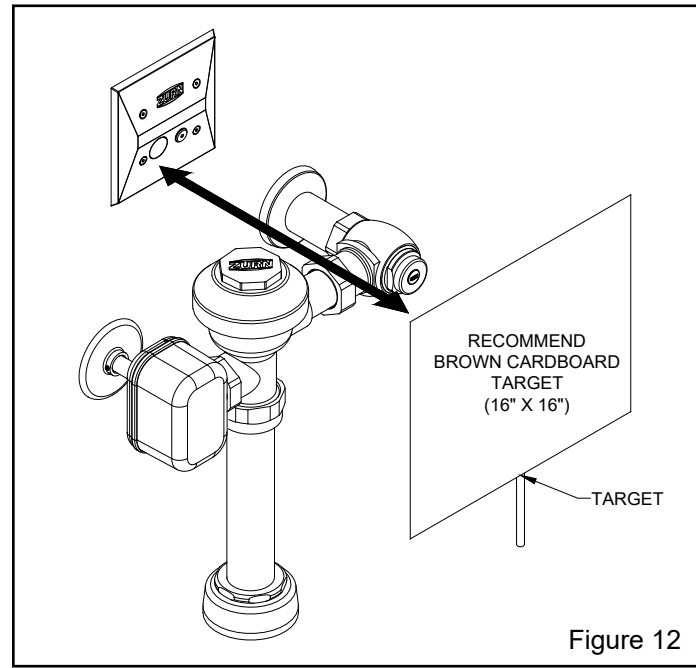

Figure 12

Activating the Motor Actuator with the Sensor

To activate the motor actuator with the sensor, simply place a target in front of the sensor. A single red light will flash indicating the sensor has recognized the target. If the target stays in view for eleven seconds, two flashing red lights will occur. This indicates that the target has been in view for the required time and upon leaving the view, a signal will be sent to the motor actuator to flush the flush valve. NOTE: If the target does not stay in view for the required eleven seconds, a flush will not occur.

IMPORTANT NOTE: Excessive water flow creates noise, while too little flow will not satisfy the needs of the fixture. Proper adjustment is made when:

1. The plumbing fixture is cleansed after each flush without splashing water out from the lip.
2. A quiet flushing cycle is achieved.

After adjustment: Replace the Zurn stop cap screw cover.

Care and Cleaning Instructions

Do not use abrasive or chemical cleaners to clean Flushometers, sensor, and actuators as they may degrade the sensor lens, dull the luster, and attack the chrome or special decorative finishes. Use only mild soap and water, then wipe dry with a clean cloth or towel.

While cleaning the bathroom tile, the Flushometer and actuator should be protected from splattering of cleaner. Do not use acids and cleaning fluids as they can damage the optics lens and chrome plating.

Seasonal use.

Valves that are used in installations subject to shut down because of cold and freezing conditions should be maintained in the following manner.

1. Shut off the main supply.
2. Drained water.
3. Remove the stop valve cap and stop internals to allow the water to drain from the flush valve and supply line.

ZEMS G2 Trouble Shooting

Problem	Possible Cause	Corrective Action
Valve will not operate.	1) Stop valve is closed	1) Open stop valve.
	2) Supply valve is closed.	2) Open supply valve.
	3) The electric wire(s) is not connected.	3) Connect the wires.
	4) Sensor lens may be dirty.	4) Clean lens.
	5) Reflective surface in front of sensor.	5) Remove the reflective surface from in front of the sensor.
	6) Detection range not adjusted properly.	6) Adjust the detection range.
	7) The infrared sensor or the actuator is out of order.	7) Contact distributor for replacement.
	8) Sensor fault	8) Replace sensor
	9) No power provided by power supply	9) Replace power supply
Flush valve does not activate after user leaves	1) Sensor does not recognize a user	1) Re-calibrate sensor per "Calibration Instructions" section.
	2) Power supply may be disrupted	2) Check available voltage where escutcheon is attached to wall with DC voltmeter. 7.4-9 VDC is required.
	3) Verify connection to actuator.	
Repeated valve activation when power is provided	1) Insufficient DC power level (less than 7.4 volts DC)	1) Upgrade the -HW6 power supply to the new ZURN power supply (greater than 7.4 volts DC) or replace the ACA supply.
Insufficient volume of water to adequately siphon fixture	1) Stop valve is not open enough.	1) Open stop valve for desired volume of water.
	2) Urinal piston installed in closet valve.	2) Replace urinal piston with proper closet piston.
	3) Insufficient volume or pressure at supply.	3) Consult fixture guide for minimum gallons per minute flow and running pressure for satisfactory performance.
Valve is flushing too long or not shutting off.	1) Trip mechanism not seating properly due to foreign material between trip mechanism and seat.	1) Disassemble parts and rinse thoroughly.
	2) By-pass orifice is plugged or partially plugged.	2) Examine by-pass orifice and clean if necessary being certain not to enlarge orifice opening.
	3) Line pressure is not adequate to force trip mechanism to seal.	3) Pressure is inadequate or has dropped below minimum operating range. Steps should be taken to increase the line pressure.
Water splashes out of fixture/	1) Supply volume is more than is necessary.	1) Adjust downward on control stop.
	2) Lime accumulation on vortex or spreader holes of fixture.	2) Remove the lime build up.
Flush is not considered quiet.	1) Control stop may not be adjusted for quiet operation.	1) Adjust the control stop for quiet operation keeping in mind the fixture evacuation requirements.
	2) Fixture may be contributing to noise.	2) Check noise created by fixture by placing a cover over the bowl opening to separate valve noise from bowl noise. If it is determined the fixture is too noisy, consult with fixture manufacturer.
	3) Piping system may be source of noise.	3) High pressure in the system can sometimes be controlled by the stop valve. Other sources of noise may be the absence of air chamber and shock arrestors, loose pipes, improper size pipes, etc. In these cases the building engineer should be consulted.
Flush valve "ghost" flushes or activates randomly with no user present.	1) Sensor Lens may be dirty.	1) Clean lens.
	2) Power supply output is out of tolerance.	2) DC voltage must be between 7.4-9 volts. Check for power fault or malfunction in a unit or replace with a Zurn power converter.
	3) Sensor is viewing stall door.	3) Re-calibrate sensor per "Calibration Instructions" section.
Flush valve shuts off too quick.	Diaphragm Valves	
	1) Damaged diaphragm.	1) Install new P6000-ECA, P6000-EUA replacement kit.
	2) Enlarged by-pass orifice.	2) Install new P6000-ECA, P6000-EUA replacement kit.
	Piston Valves	
	1) Damaged piston.	1) Install new P6200-EC, P6200-EU replacement kit.
	2) Enlarged by-pass orifice.	2) Install new P6200-EC, P6200-EU replacement kit.
Valve is short flushing	Diaphragm Valves	
	1) Enlarged by-pass orifice.	1) Install new P6000-ECA, P6000-EUA replacement kit.
	2) Urinal piston installed in closet valve.	2) Replace urinal piston with proper closet piston.
	Piston Valves	
	1) Enlarged by-pass orifice.	1) Install new P6200-EC, P6200-EU replacement kit.
	2) Urinal piston installed in closet valve.	2) Replace urinal piston with proper closet piston.



ZEMS G2 Valves Parts List

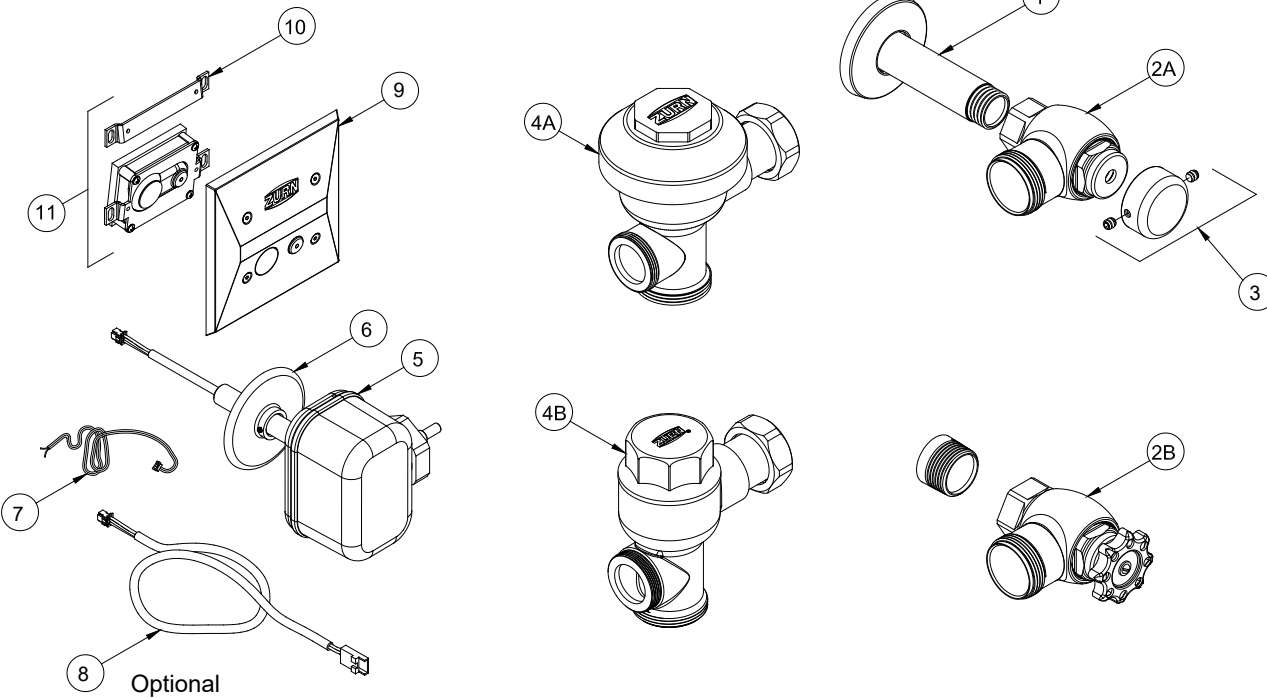

ZEMS G2 Valve Parts List (Continues)

1.	P6000-YBYC P6003-YBYC	Closet Cast Wall Escutcheon & Solder Kit Urinal Cast Wall Escutcheon & Solder Kit		
2A.	P6000-C-SD-CP P6003-C-SD-CP P6000-C-SD-RB P6003-C-SD-RB	Chrome Plated Closet Stop Assembly Chrome Plated Urinal Stop Assembly Rough Brass Closet Stop Assembly Rough Brass Urinal Stop Assembly		
2B.	P6000-C-WH-CP P6003-C-WH-CP P6000-C-WH-RB P6003-C-WH-RB	Chrome Plated Closet Stop Assembly for Wheel Handle Chrome Plated Urinal Stop Assembly for Wheel Handle Rough Brass Closet Stop Assembly for Wheel Handle Rough Brass Urinal Stop Assembly for Wheel Handle		
3.	P6000-VC	Vandal-Resistant Control Stop Cover		
4A.	Varies(Z60__,Z61__)	Diaphragm Valve		
4B.	Varies(Z62__)	Piston Valve		
5.	PEMS6000-HYM-G2	ZEMS Actuator		
6.	PEMS6000-G	ZEMS Escutcheon		
7.	PEMS6000-CWB-G2	Sensor Power Supply Cable		
8.	PEMS6000-CW-G2	Motor-Sensor Connector Extension Cable, 24" (Optional) (Max 2 per installation)		
9.	PEMS6000-22-G2	ZEMS Sensor Plate with fasteners		
10.	PEMS6000-22-KIT-G2	ZEMS Top Bracket with fasteners		
11.	PEMS6000-26-G2	ZEMS Sensor with top bracket and fasteners		
12A.	P6000-A-AA-CP	Chrome Plated 1-1/2" X 8 1/2" Vacuum Breaker Assembly		
	P6000-2-A-AA-CP	Chrome Plated 1-1/2" X 21" Vacuum Breaker Assembly		
	P6000-3-A-AA-CP	Chrome Plated 1-1/2" X 24" Vacuum Breaker Assembly		
12B.	P6001-A-AA-CP	Chrome Plated 1-1/4" X 8 1/2" Vacuum Breaker Assembly		
12C.	P6003-A-AA-CP	Chrome Plated 3/4" X 8 1/2" Vacuum Breaker Assembly		
12D.	P6000-1-A-AA-RB	Rough Brass 1-1/2" X 12 1/2" Vacuum Breaker Assembly		
12E.	P6000-A-AA-RB	Rough Brass 1-1/2" X 5" Vacuum Breaker Assembly		
12F.	P6001-10-A-AA-RB	Rough Brass 1-1/4" X10" Vacuum Breaker Assembly		
12G.	P6003-10-A-AA-RB	Rough Brass 3/4" X 10" Vacuum Breaker Assembly		
13A.	P6000-H	1 1/2" Spud Coupling Assembly		
13B.	P6001-H	1 1/4" Spud Coupling Assembly		
13C.	P6003-H	3/4" Spud Coupling Assembly		
14A.	P6000-QE3-RB	Rough Brass 1 1/2" Slip Elbow Assembly		
14B.	P6000-QE3-CP	Chrome Plated 1 1/2" Slip Elbow Assembly		
15A.	P6000-QT1-xx	Chrome Plated Slotless Tube		
15B.	P6000-QT3-xx	Rough Brass Slotless Tube		
16.	Varies	Rough Brass Slip Elbow		
17.	P6000-B-HP	Vacuum Breaker		

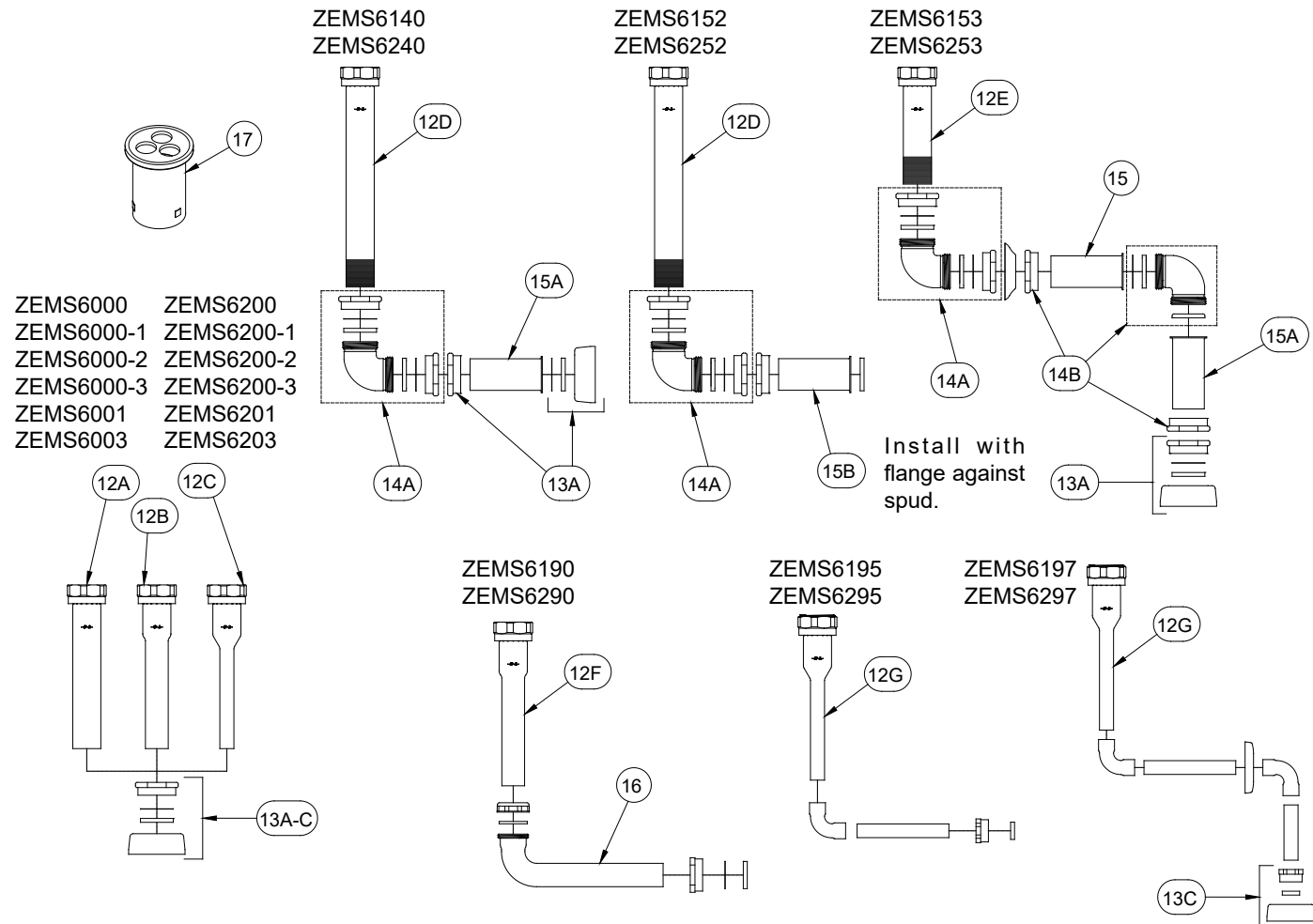

Z6000 Series

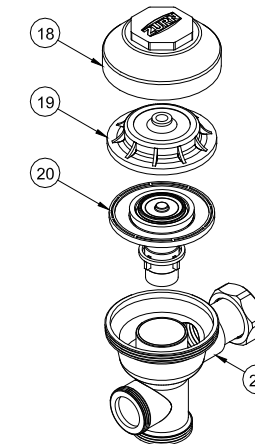

Diaphragm Valves (Z6000 Series)

18.	P6000-LL-CP P6000-LL-RB	Chrome Plated Valve Body Outside Cover Rough Brass Valve Body Outside Cover
19.	P6000-L	Valve Body Inside Cover
20.	P6000-ECA-WS P6000-ECA-WS1 P6000-ECA-HET P6000-EUA-WS P6000-EUA-WS1 P6000-EUA-EWS P6000-EUA-ULF P6000-19__	Closet Repair Kit (3.5 gpf) Low Consumption Closet Kit (1.6 gpf) High Efficiency Closet Kit (1.28 gpf) Urinal Repair Kit (1.5 gpf) Low Consumption Urinal Kit (1.0 gpf) High Efficiency Urinal Kit (0.5 gpf) Pint Urinal Kit (0.125 gpf) Valve Body

Piston Valves (Z6200 Series)

22.	P6200-LL-CP P6200-LL-ULF-CP	Valve Body Cover .125 gpf Valve Body Cover
23.	P6200-LL-CG	Valve Body Cover Gasket
24.	P6200-EC-WS1 P6200-EC-HET P6200-EU-WS1 P6203-EU-EWS P6203-EU-ULF	Low Consumption Closet Kit (1.6 gpf) High Efficiency Closet Kit (1.28 gpf) Low Consumption Urinal Kit (1.0 gpf) High Efficiency Urinal Kit (0.5 gpf) Ultra Low Flush Kit (.125 gpf)
25.	P6000-S-30 P6200-MS-ULF	Main Seat .125 gpf Main Seat
26.	Varies	Valve Body
27.	PTR6203-FA-LF	Urinal 0.125/0.250 gpf Tailpiece filter

Z6200 Series

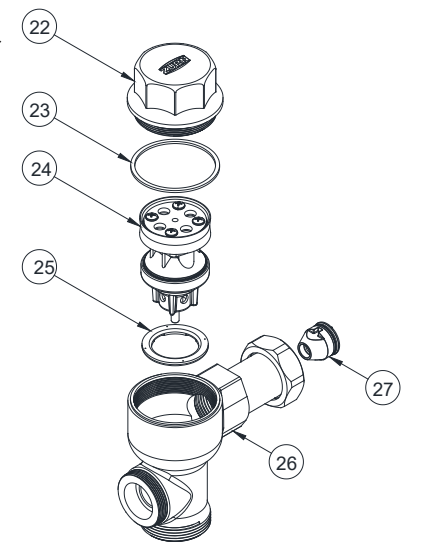

Valve Repair Parts List (Continues)

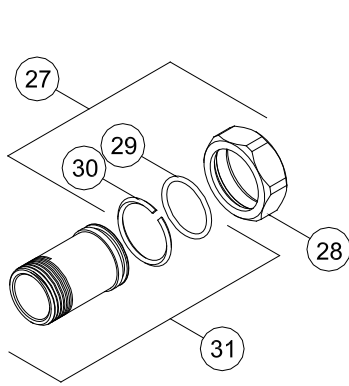

- 27. P6000-K Tailpiece Coupling Assembly
- 28. P6000-C32-CP Chrome Plated Locking Nut
P6000-C32-RB Rough Brass Locking Nut
- 29. P6000-C31 Tailpiece O-Ring
- 30. P6000-C30 Snap Ring
- 31. P6000-J Adjustable Tailpiece Assembly
- 32. P6000-YC 1" Cast Wall Escutcheon
P6003-YC 3/4" Cast Wall Escutcheon

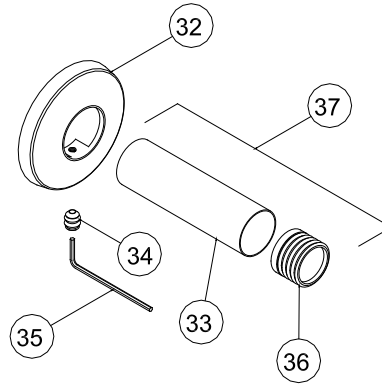

- 33. P6000-YB-CVR 1" Supply Cover Tube
P6003-YB-CVR 3/4" Supply Cover Tube
- 34. P6000-YC-SS Setscrew for Cast Wall Escutcheon
- 35. P6000-VC-W-VP 5/64 Allen Wrench
- 36. P6000-YBA 1" Sweat Solder Adapter
P6003-YBA 3/4" Sweat Solder Adapter
- 37. P6000-YB 1" Sweat Solder Kit
P6003-YB 3/4" Sweat Solder Kit

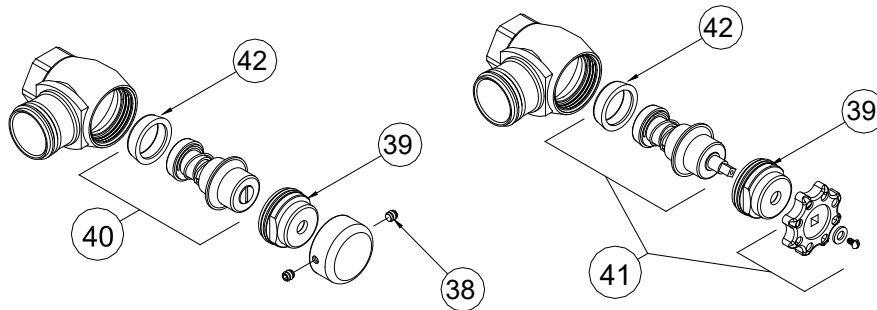

- 38. P6000-VC-SS Set Screw for Control Stop Cover
- 39. P6000-C34-CP Chrome Plated Stop Cap Bonnet
P6000-C34-RB Rough Brass Stop Cap Bonnet
- 40. P6000-D-SD Stop Cap Internals
- 41. P6000-D-WH Stop Cap Internals with Wheel Handle
- 42. P6000-D42 Stop Seat