



Camaya Series™ Soap Dispenser

Sensor-Operated Lavatory Soap
Dispenser Installations.

Installation, Operation, Maintenance,
and Parts Manual



Z6953-SD
Camaya Series™

**Sensor-Operated
Lavatory Soap Dispenser**

LIMITED WARRANTY

All goods sold hereunder are warranted to be free from defects in material and factory workmanship for a period of three years from the date of purchase. Decorative finishes warranted for one year. We will replace at no costs goods that prove defective provided we are notified in writing of such defect and the goods are returned to us prepaid at Sanford, NC, with evidence that they have been properly maintained and used in accordance with instructions. We shall not be responsible for any labor charges or any loss, injury or damages whatsoever, including incidental or consequential damages. The sole and exclusive remedy shall be limited to the replacement of the defective goods. Before installation and use, the purchaser shall determine the suitability of the product for his intended use and the purchaser assumes all risk and liability whatever in connection therewith. Where permitted by law, the implied warranty of merchantability is expressly excluded. If the products sold hereunder are "consumer products," the implied warranty of merchantability is limited to a period of three years and shall be limited solely to the replacement of the defective goods. All weights stated in our catalogs and lists are approximate and are not guaranteed.

NOTICE: READ ENTIRE MANUAL PRIOR TO INSTALLING PRODUCT.

⚠ WARNING: Cancer and Reproductive Harm - www.P65Warnings.ca.gov

⚠ ADVERTENCIA: Cáncer y daño reproductivo - www.P65Warnings.ca.gov

⚠ AVERTISSEMENT: Cancer et effets néfastes sur la reproduction - www.P65Warnings.ca.gov

NOTE: The information in this manual is subject to change at any time without notice. Installations may be performed at different times of construction by different individuals. For this reason, these instructions should be left on-site with the facility or maintenance manager.

Rev. B | Date: 07/10/24 | C.N. No. 146175 | Prod./Dwg. No. FV624

Patent zurn.com/patents

US 1.855.0NE.ZURN CANADA 1.877.892.5216

ZURN.COM

by **ZURN ELKAY** Water Solutions

Specifications

Power Supply: AC110V; DC 6V
DC 6V (4x "D" Cell Alkaline Batteries)

Soap Bottle Volume: 1600 mL

Operating Temperature: 35°F to 104°F [2°C to 40°C]

Dispensed Volume: 2 ml Max (4 Adjustable Settings)

Soap Viscosity: 100 - 3500 cPs

Important Safety Information

- Do not convert or modify this Zurn product. All warranties will be voided.
- All plumbing is to be installed in accordance with applicable codes and regulations.
- Sensor units should not be located across from each other or in close proximity to highly reflective surfaces.

Optional Accessories



Magic Magnet
P6900-AT-MAG

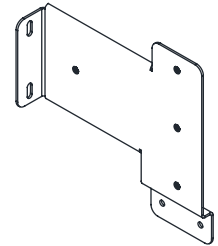

Stud Mounting Bracket
P6900-SD-BKT

Required Tools

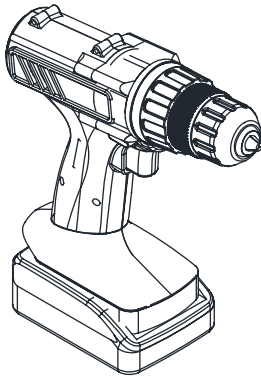

Hand Drill

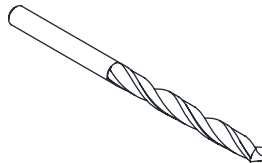

Drill Bits
-3/16", 1 1/4"

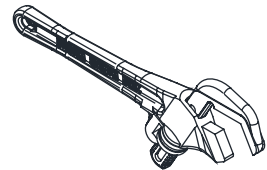

Smooth Jawed
Wrench

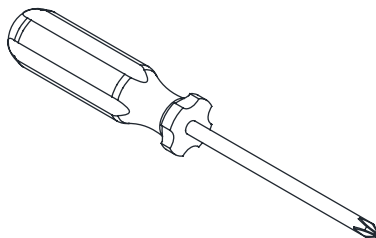

Phillips Head
Screwdriver

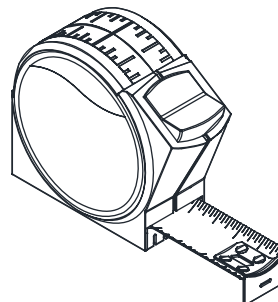

Measuring Tape

Package Contents

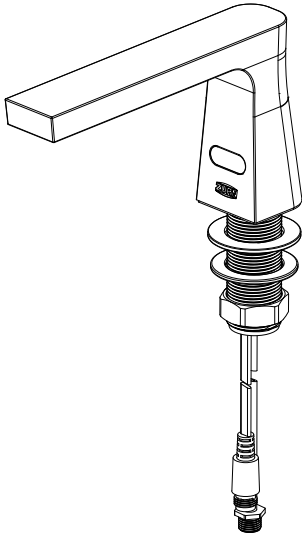

Camaya Liquid Soap Dispenser Assembly

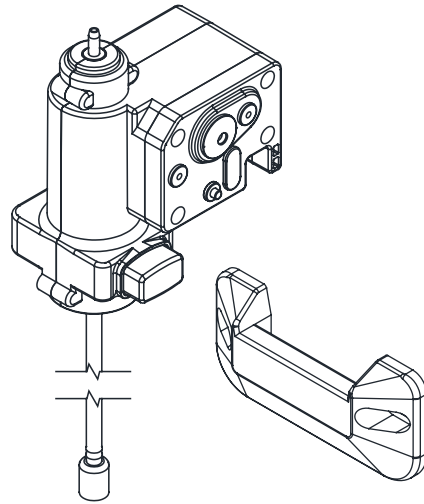

Control Box Assembly & Mounting Bracket

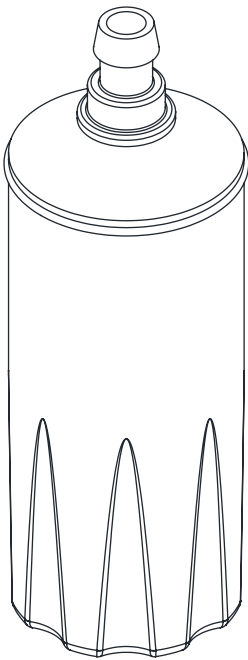

Soap Bottle

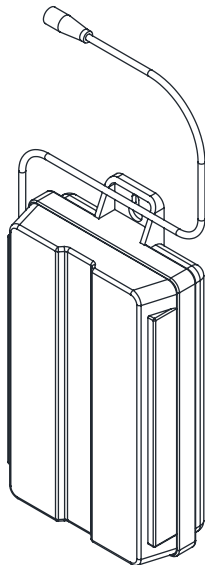

Battery Enclosure

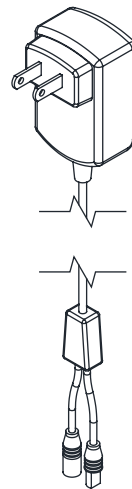

AC Adapter

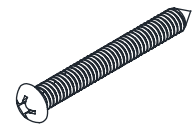

6x Mounting Screws

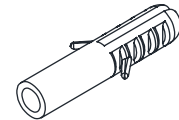

6x Plastic Wall Anchors



2x Hose Clamps

Spout Installation

1. Feed the sensor cable and soap tube through the mounting hole in the basin or counter top. Install the mounting shank through the hole and align the dispenser with the basin.

Note: The recommended through hole for this dispenser is 1" - 1 1/4"

Install the rubber gasket and brass washer over the mounting shank as shown. Tighten the hex nut to secure the dispenser in place.

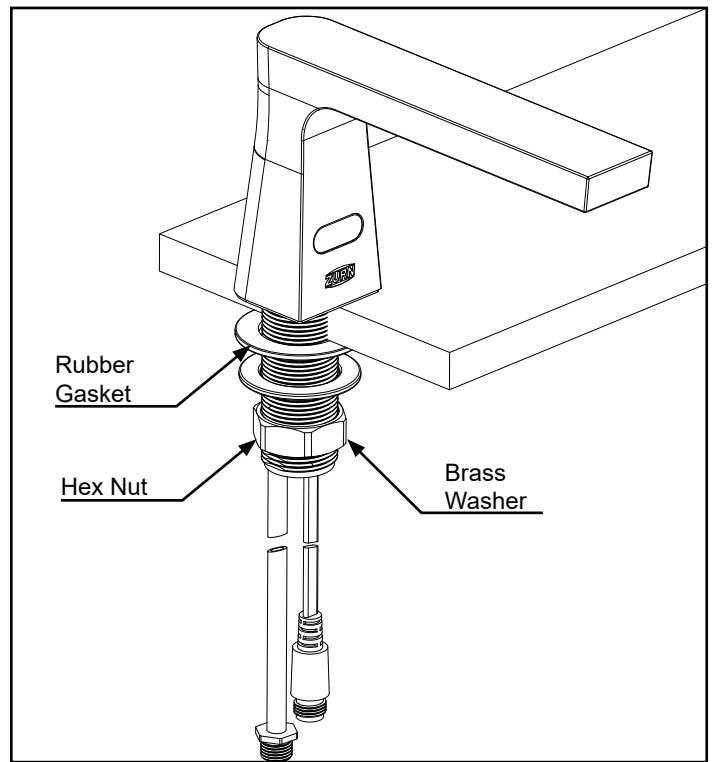

Control Box Installation

1. **Note: It is recommended to test fit the assembly prior to installation to avoid interference with other components.**

Place the wall hanger on the wall as a guide and mark the location of the screw holes. Drill 3/16" holes on the marks. Insert the anchors into the holes, flush with the wall. Attach the wall hanger to the wall with the supplied screws.

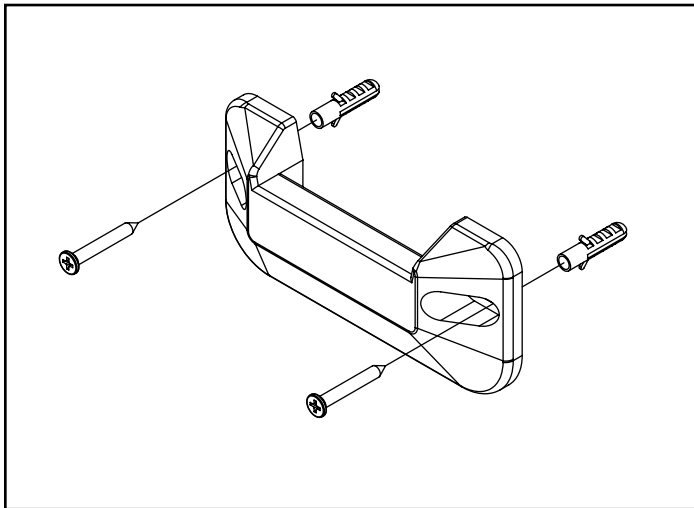

2. Hang the control box on the wall hanger. Ensure the control box is properly engaged with the wall hanger.

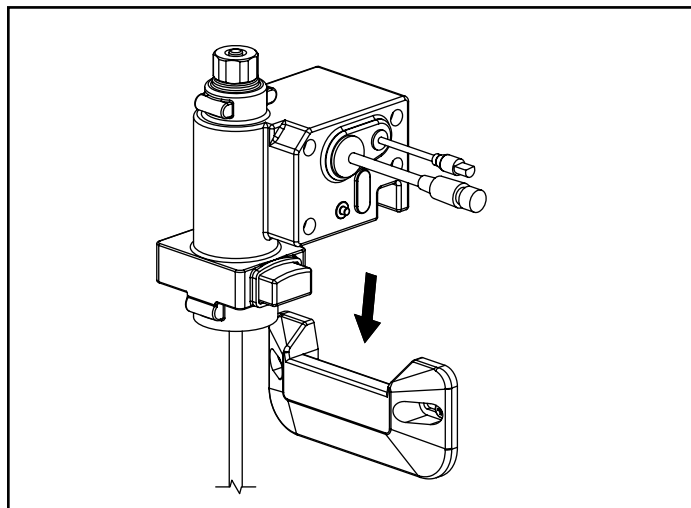

3. Connect the sensor cable from the dispenser to the control box. Press the two connectors together and tighten the cable nut.

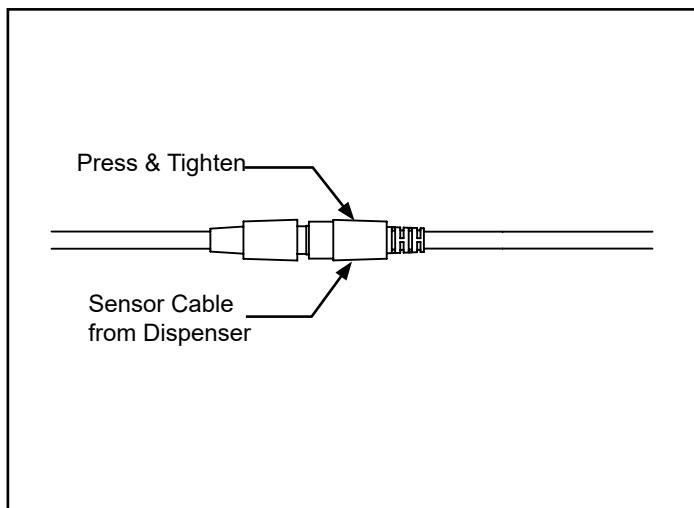

4. Connect the soap tube from the dispenser to the control box at the soap connection on top. It is important to tighten this connection sufficiently to avoid leaks.

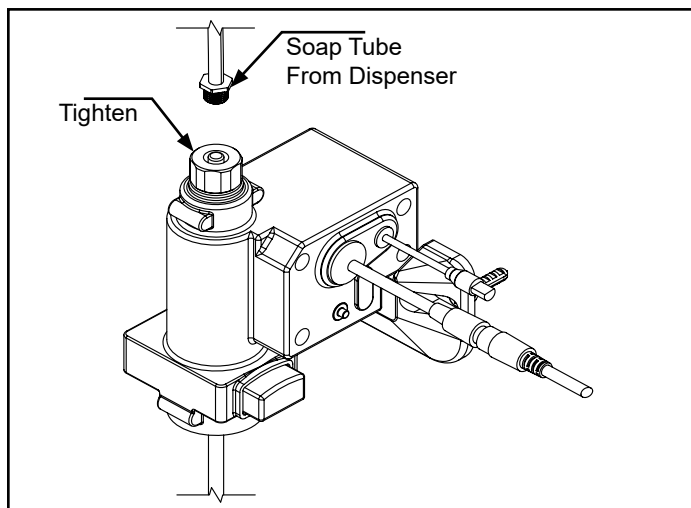

5. **Note: This step is only necessary if utilizing the battery pack to power the unit. Mount the battery pack in an easily accessible area.**

Place the battery pack on the wall as a guide to mark the screw holes. Drill 3/16" holes on the marks. Insert the anchors into the wall, flush with the wall. Attach the battery pack to the wall with the supplied screws.

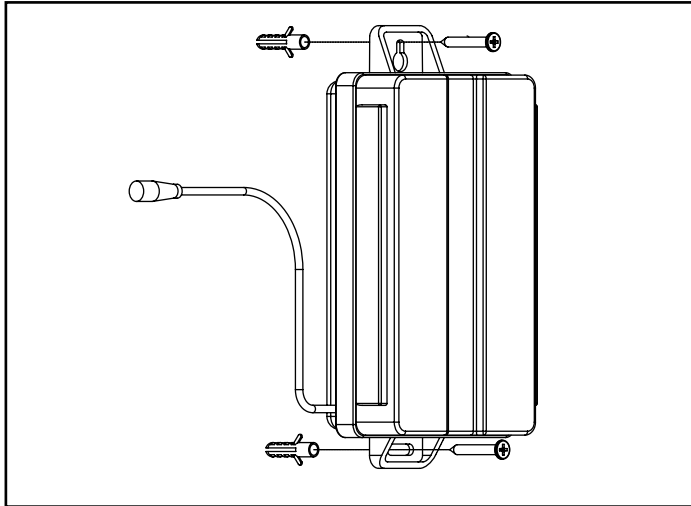

3. Connect the sensor cable from the dispenser to the control box. Press the two connectors together and tighten the cable nut.

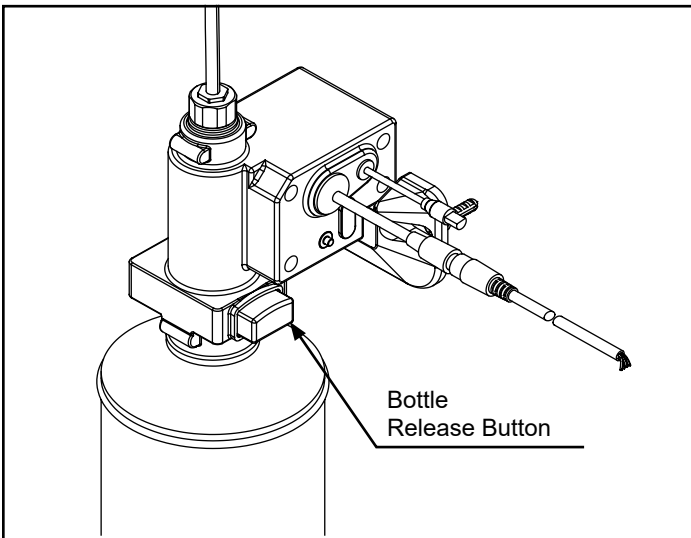

6. Attach the power supply to the control box. This dispenser can be powered in one of three ways: A/C adapter, battery pack, or A/C with a battery backup.

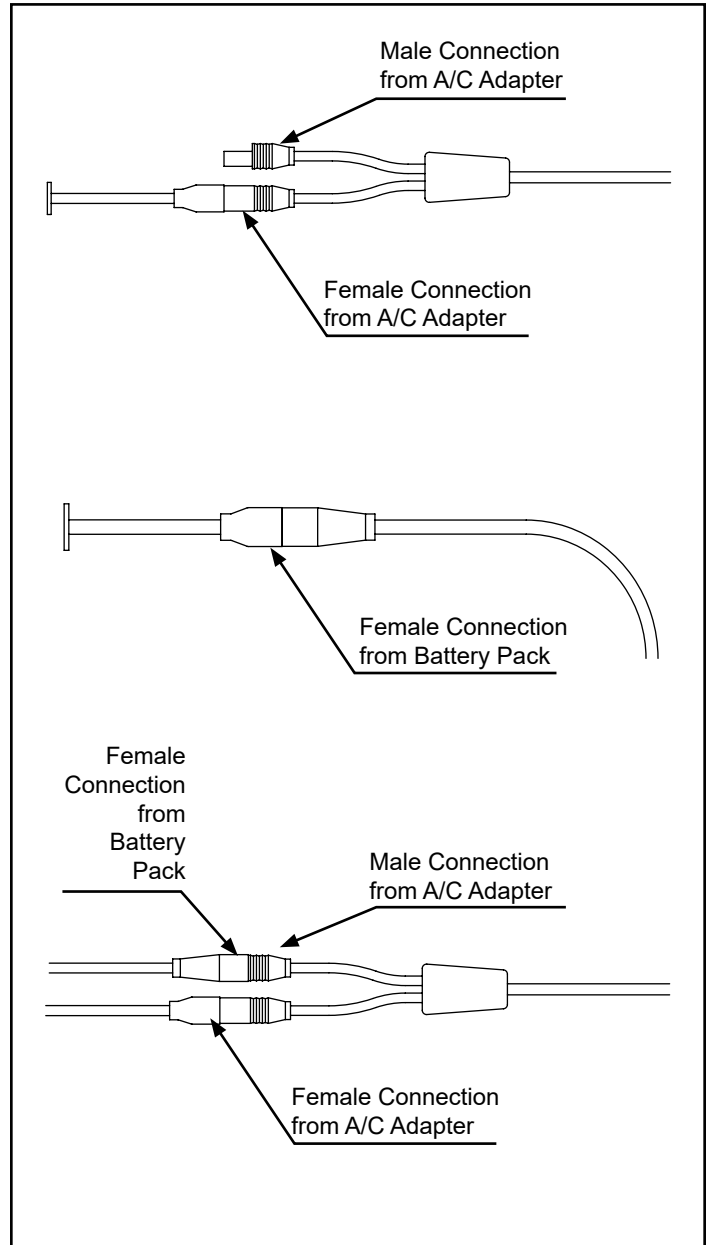

- Re-attach the bottle to the control box, making sure that the soap input tube is inside the soap bottle. Depress the system prime button until soap comes from the nozzle. The system is now primed and ready to use.

Note: It may be necessary to first prime the system with water if using thicker soaps.

- The dispenser has four settings to control the amount of soap that is dispensed. Setting one is the smallest volume and setting 4 is the largest volume. Lift the cover to expose the dip switches. The desired setting is achieved by setting the switches to the settings as shown.

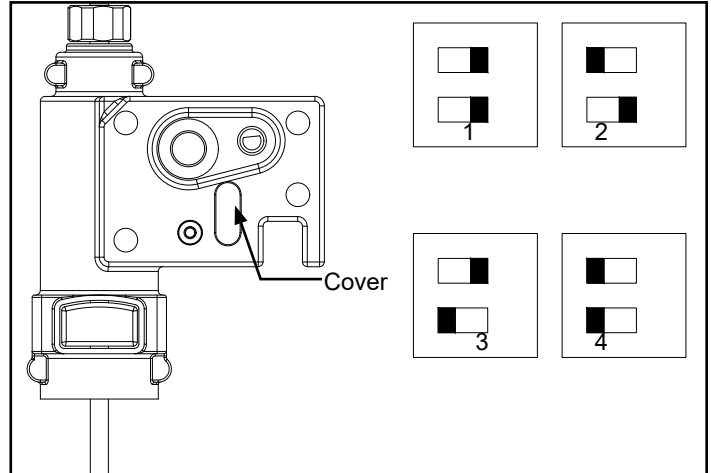
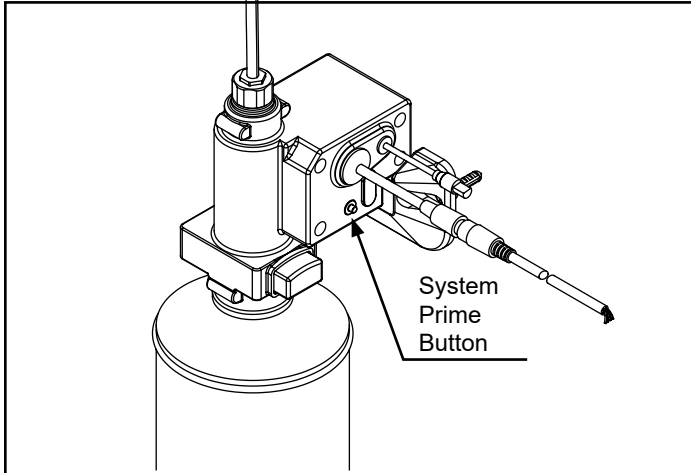

Soap Volume Adjustment

The Camaya Liquid Soap Dispenser has four dispense volume settings. To access the Dip Switches for adjustment, remove the plastic boot located on the side of the control box.

Adjust the dispense volume by manipulating DIP switches according to the table provided below:

Dispense Volume	DIP switch #1	DIP switch #2
Low Volume	OFF	OFF
Normal Volume (Default)	OFF	ON
Medium Volume	ON	OFF
High Volume	ON	ON

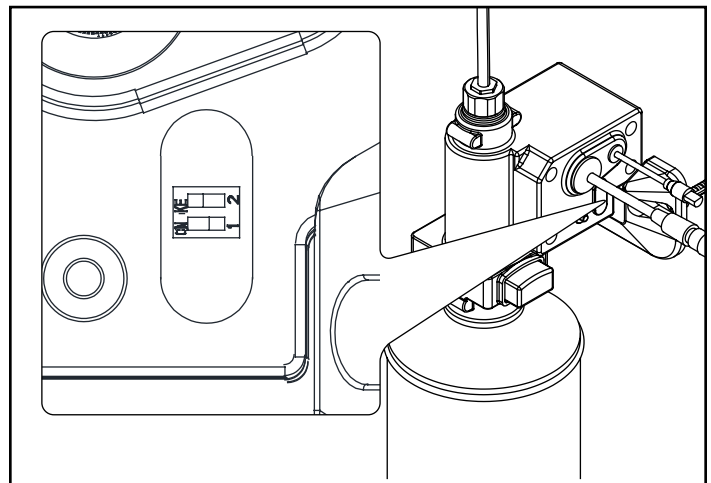

Adjusting Calibration Distance

Each Camaya Liquid Soap Dispenser comes calibrated from the factory to work optimally in most restroom environments. In low light or highly reflective environments. However, it may be necessary to adjust the calibration distance at times. To do this, a Zurn Magic Magnet may be used. To re-calibrate a Camaya Liquid Soap Dispenser with a Magic Magnet, follow the procedure below:

- Hold a piece of white cardboard at the desired calibration distance:
- Raise the Magic Magnet to the front of the sensor lens until LED flashing.
- Remove the Magic Magnet and allow the LED to flash rapidly while keeping the cardboard at the same position. The calibration is finished when the LED stops flashing.

Optional Stud Mounting Bracket Installation

Zurn P6900-SD-BKT Stud Mounting Bracket can be incorporated with the provided standard control box mounting bracket to install in 4 different orientation to fit the soap dispenser control box assembly under the lavatory.

Reference any of the steps below based on your specific circumstance to mount the assembly.

1. Test fit the full assembly to determine the optimal orientation of P6900-SD-BKT Stud Mounting Bracket.
2. Attach the Control Box Mounting Bracket to P6900-SD-BKT Stud Mounting Bracket with the two provided machine screws.
3. Secure the P6900-SD-BKT Stud Mounting Bracket onto wooden wall studs using the slots or mounting holes with the provided thread forming screws. If the wall studs are made of different materials, use any appropriate commercially available mounting hardware.

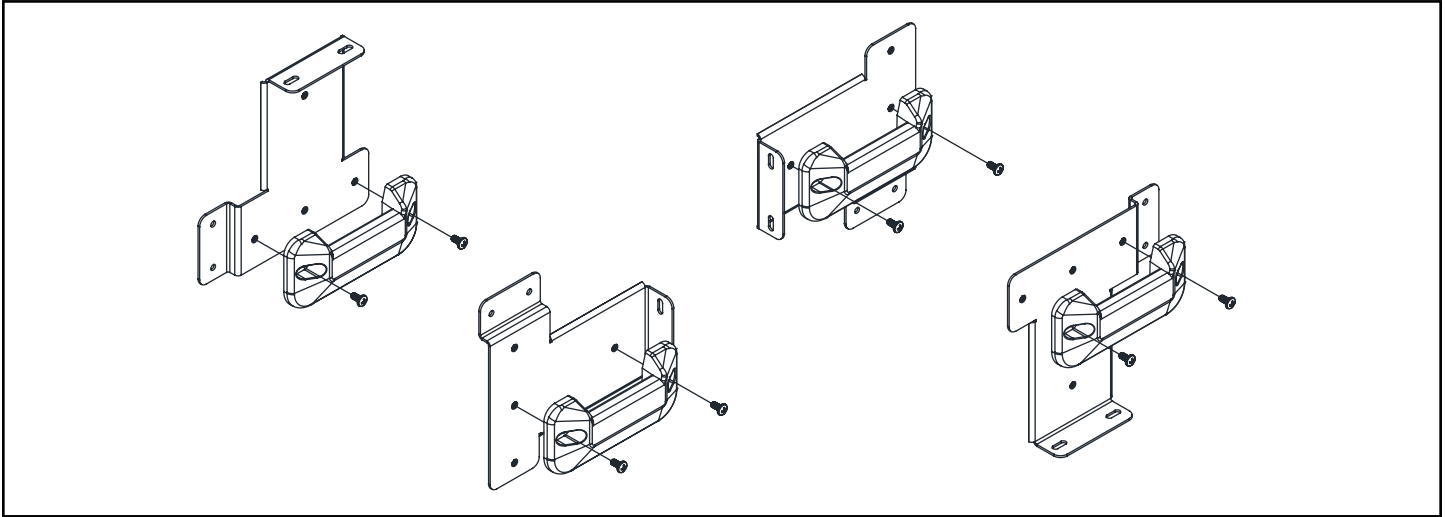

Care and Cleaning Instruction

- Do not use any abrasive or chemical cleaners to clean the soap dispenser.
- If abrasives or chemicals are used it can lead to dulling of luster, attacking of chrome plating or decorative finishes.
- ONLY use mildly warm soapy water, and then wipe the device dry with a clean/soft towel or cloth.
- Upon cleaning other areas of the restroom be sure the sensor lenses are protected from other cleaning chemicals/solvents to prevent potential damages to the sensor and/or electronics.
- It is recommended to flush the system with warm water every 3 to 6 months.
 - With a minimal amount of soap in the soap bottle, fill the soap bottle with warm water.
 - Re-attach the soap bottle to the control box and press the dispense button. Hold the button down until all of the water has been flushed through the system.
 - Refill the soap bottle with soap and press the dispense button. Hold down the button until any residual water ins pushed through the pump and soap is being dispensed. The dispenser is now ready to use.

Trouble Shooting Guide

PROBLEM	CAUSE	SOLUTION
No Soap Dispensed	There is air in the soap supply tube	Activate the sensor repeatedly until soap dispensed.
	Ambient temperature too low, soap is frozen.	Fill in small amount of warm water (About 140 °F)
	Not sufficient soap in soap bottle.	Refill soap bottle
	Soap too viscous	Substitute soap with the appropriate viscosity as indicated in viscosity range on page 1
Continuous flow of soap.	Object detecting by sensor	Remove object or clean sensor lens
Short Battery Cycle	Incorrect Batteries	Change to 4 "D" cell alkaline batteries

Rev. B | Date: 07/10/24 | C.N. No. 146175 | Prod./Dwg. No. FV624

Patent zurn.com/patents

US 1.855.0NE.ZURN CANADA 1.877.892.5216

ZURN.COM

by ZURN ELKAY Water Solutions