



# Model HBRV

## Hose Bibb Relief Valve

### Application

The Zurn Wilkins Model HBRV is designed for installation on washing machine fill valve to provide protection from thermal expansion. The HBRV is to be threaded on the cold water washing machine fill valve using an adapter (not provided). The washing machine fill hose is then attached to the HBRV. The device is for pressure relief only and should be used in conjunction with other temperature limiting devices.

### Materials

Body Brass ASTM B 927 UNS C27450  
 Spring Stainless Steel, 302 series  
 Seat washer Buna Nitrile (FDA approved)  
 Plunger & screw Brass ASTM B 16

### Features

Sizes: 3/4"  
 Maximum working water pressure 125 PSI  
 Maximum working water temperature 180°F  
 Threaded Connections

ANSI B1.20.1 (NPT)  
 ANSI B1.20.7 (Hose Thread)

100-HBRV Supplied with male NPT x Male hose thread body connection, with integral relief valve.

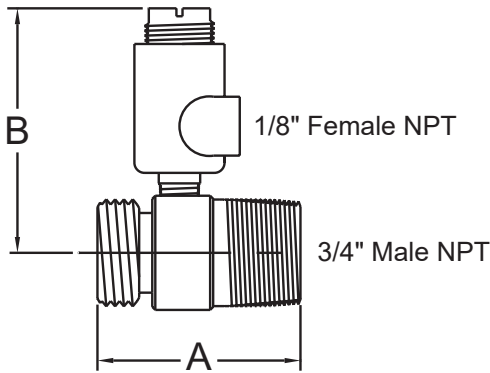

MODEL 100-HBRV

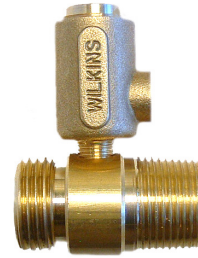

MODEL 100-HBRV

### Options

- 80 - with 80 psi relief setting
- 100 - with 100 psi relief setting

### Accessories

- Water Hammer Arrestor (Model 1250XL)
- Water Pressure Reducing Valve (Model NR3XL)
- Temperature and Pressure Relief Valve (Model TP1100A)

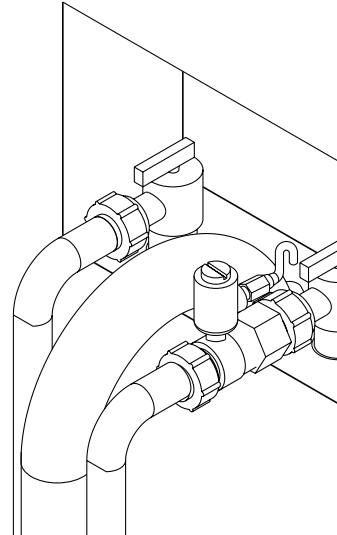

### Dimensions & Weights (do not include pkg.)

MODEL	DIMENSIONS (approximate)				WEIGHT	
	A		B			
	in.	mm	in.	mm	lbs.	kg
100-HBRV	2	50.8	2 7/16	62	0.6	0.27

### Typical Installation

Local codes still govern installation requirements. Assembly shall be installed with discharge lines terminating at an adequate drain with proper air gap.