



Model 375ASTW1 (Connected Backflow w/ Wireless Monitor)



Reduced Pressure Principle Assembly with Integral Relief Valve Monitor

Architectural/Engineering Specification:

Zurn Connected Backflow with Relief Valve Monitors

transmit data 24/7 to the Zurn plumbSMART™ web portal and mobile app. Proactively monitor your relief water discharge and system pressure data, receive real-time alerts for preset discharge volumes and low pressure parameters, and access system data for trends and predictive maintenance anytime and anywhere.

Zurn Model 375ASTW1 Reduced Pressure Principle Backflow Preventer with Relief Valve Monitors provide high hazard protection and are ideal for use in Mechanical rooms, basements and enclosures where undetected relief valve discharge could potentially cause water damage. The responsive electronics controller constantly monitors zone pressure and the relief valve discharge to determine if a fouled check valve or water hammer is causing a relief valve discharge.

Product Features: plumbSMART™ Portal

- Monitor discharge volume and pressure anywhere in your building
- Receive real-time alerts
- Manage maintenance tasks
- Receive insights on your data

375ASTW1 Sizes: 2 1/2", 3", 4", 6", 8", 10"

Technical Specification:

Maximum working water pressure 175 PSI
 Maximum working water temperature 140°F
 Hydrostatic test pressure 350 PSI
 End connections

(Grooved for steel pipe) AWWA C606
 (Flanged Bolt Pattern) ASME B16.42
 Class 150

Electrical Requirements:

Input Power Supply: 100 – 126V AC, 50/60Hz; 375 mA
 Output Voltage: 4.0V DC; 0.44A
 Operating Temperature: 20°F to 120°F
 Storage Temperature: -4°F to +175°F
 Relative Humidity: 10% – 90%
 Pressure Sensor: Mounted on main backflow valve
 Position Sensor: Mounted on main relief valve

Zurn Gateway:

- Communicates via Ethernet or LTE
- Works with all Zurn connected devices
- Connects all endpoints up to 1,000 ft radius
- After purchase request your gateway at: zurn.com/plumbsmart-gateway or Call 1-844-987-6737



Model 375ASTW1

See **Model FCIS** spec sheet to combine with ACV for automatic flood control shutdown system



NSF/ANSI/CAN 61



Options

(Suffixes can be combined)

- with flanged end NRS gate valves (standard)
- G - with grooved end NRS gate valves
- GF - with grooved inlet gate connection and flanged outlet gate connection
- FG - with flanged inlet gate connection and grooved outlet gate connection
- OSY - with flanged end OS&Y gate valves
- OSYG - with grooved end OS&Y gate valves
- BG - with grooved end butterfly valves with integral supervisory switches
- BF - with flanged end butterfly valves with integral supervisory switches
- R - with replacement spool (custom length) (see 375ASTR spec sheet for available lengths)

Accessories

- OS & Y Gate valve tamper switch (OSY-40)
- Air gap (Model AG)
- Wireless Monitor Retrofit Kit for Conversion of existing model 375 (212-6-RFK-375W1, 8-10-RFK-375W1)

Compliance and Certification

- Approved by the Foundation for Cross Connection Control and Hydraulic Research at the University of Southern California
- AWWA Compliant C511 (with gates only) and C550
- ASSE® Listed 1013
- cUPC® Listed
- Meets the requirements of NSF/ANSI/CAN 61*
 *(0.25% MAX. WEIGHTED AVERAGE LEAD CONTENT)

This device complies with Part 15 of the FCC Rules and ISSED Canada RSS Standards.

Gateway Options

(Required & Sold Separately)

- LTE ZGW-LORA-W1-LTE
- Ethernet ZGW-LORA-W1-ETH

Note: plumbSMART™ is free-to-connect to a basic plan
Note: LTE charges will apply to basic plan

How it works

The Model 375ASTW1 Connected Backflow with Wireless Monitor continuously monitors relief water discharge and system water pressure. Once per hour, water pressure data is transmitted to the plumbSMART™ portal. Facilities managers and/or maintenance personnel can view all data and trends in the plumbSMART™ portal and may opt to receive real-time alerts via email or text message if any of these readings exceed or fall below customizable parameters for high and low pressure levels. All notifications and alert parameters are adjustable via the plumbSMART™ portal. For more information, visit <https://www.zurn.com/innovation-efficiency/plumbsmart>.

Zurn Connected plumbing products are equipped with advanced sensors that track product usage and performance. This data is transmitted wirelessly via the built-in LoRa radio system to a Zurn Gateway, which then sends the data to the Zurn Cloud via Ethernet connection to the local area network (LAN) or via LTE cellular. The LTE cellular option means the data never touches your local network. Algorithms in the Zurn Cloud analyze the data, which is displayed on our secure web portal and mobile app, plumbSMART™. Zurn Connected plumbing products and data from plumbSMART™ may be customized to communicate with existing building management systems (BMS), depending on the communication protocols in use. Each Zurn Connected plumbing product comes with default alert parameters for water pressure, product usage, etc. Alert parameters can be customized in plumbSMART™ based on the specific needs of your building and maintenance protocols. Depending on the functionality of the equipment, some Zurn Connected Products can sense when to act in order to protect your building.

To access the plumbSMART™ portal, a Zurn Gateway must be installed within 1,000 feet of the connected product, and Connected products must be registered with Zurn plumbSMART™. A single Zurn Gateway can be used to connect hundreds of Zurn Connected plumbing products.

Connecting to the plumbSMART™ Portal:

1. Document the serial number from the label inside the electronics enclosure. The serial number is printed on the left side of the label below the QR code.
2. Visit www.zurn.com/plumbSMART-connect to save time and money on your installation. You can also call us at 844-987-6737.
3. Provide the serial number and contact name, email address, and basic information about the installation site.
4. We will activate your plumbSMART™ account, set up your enterprise, and give you guidance on how to register each connected product as you install it.
5. We will send a confirmation email with a link, or you can go to plumbsmart.zurn.com to log into your plumbSMART™ account for the first time.
6. Add other users and installers to your plumbSMART™ account.
7. Make sure you and/or your installers have the plumbSMART™ mobile app, which you can download from the iPhone App Store or Google Play.
8. Using the mobile app, scan or enter the serial number to register and locate each connected plumbing product as you install it.
9. Watch the how-to videos in the plumbSMART™ portal's support section if you get stuck, or call us at 844-987-6737 for support.



MODEL 375ASTW1 2 1/2", 3", 4" & 6" (STANDARD & METRIC)

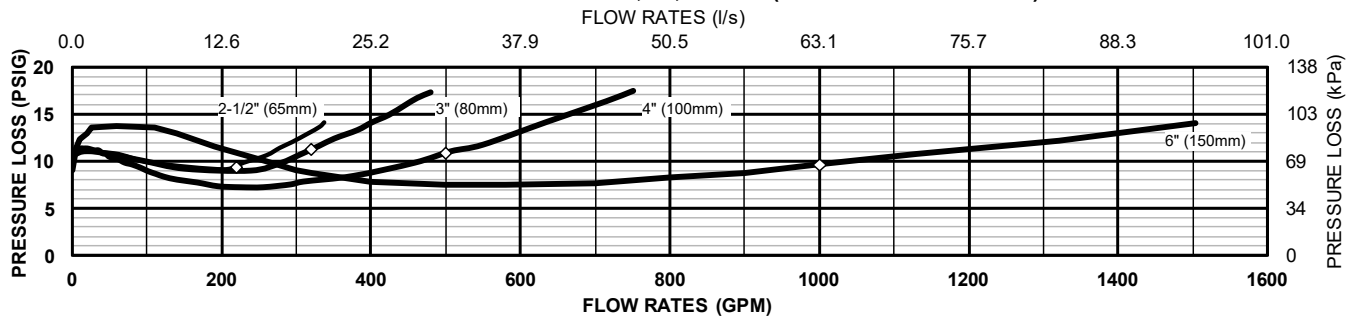

MODEL 375ASTW1 8" & 10" (STANDARD AND METRIC)

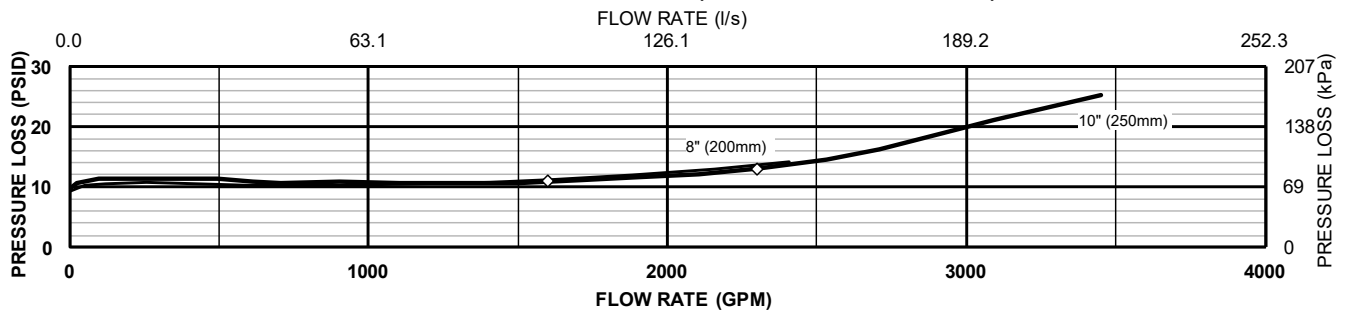

Relief Valve Discharge Rates

(Worst case condition - If 1st check or relief valve is lodged wide open)

**Model 375 & 475 RP & RPDA
Backflow Preventers**

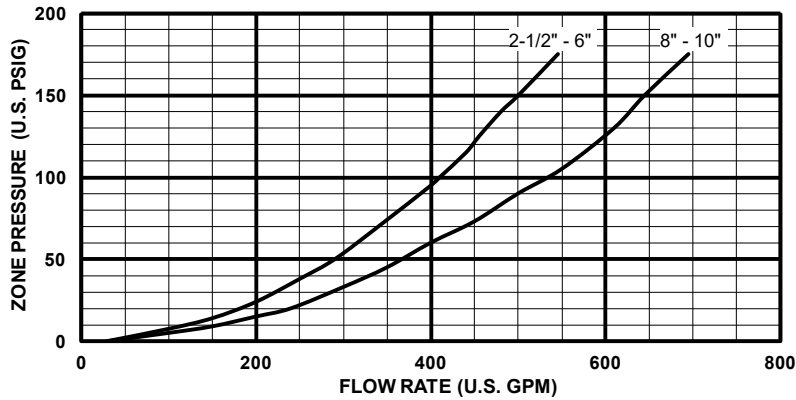

Materials

Main valve body	304L Stainless Steel
Access covers	304L Stainless Steel
Coatings	FDA Approved electrostatic epoxy finish
Internals	Stainless Steel, 300 Series NORYL™
Fasteners & Springs	Stainless Steel, 300 Series
Seal rings	EPDM (FDA approved)
O-rings	Buna Nitrile (FDA approved)
Sensing line	Stainless Steel, braided hose
Switch Cover	Nylon, UV resistant, glass filled

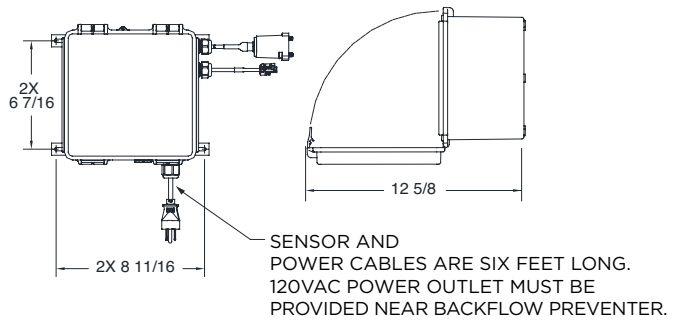

Dimensions & Weights (does not include pkg.)

MODEL 375ASTW1 SIZE	WEIGHT														
	WITH-OUT GATES		WITH NRS GATES (GXF)		WITH OS&Y GATES (GXF)		WITH NRS GATES (GXG)		WITH OS&Y GATES (GXG)		WITH BUTTERFLY VALVES (GXG)		WITH BUTTERFLY VALVES (GXF)		
in.	mm	lbs.	kg	lbs.	kg	lbs.	kg	lbs.	kg	lbs.	kg	lbs.	kg	lbs.	kg
2 1/2	65	44	20	105	47	123	56	95	43	113	51	90	41	100	45
3	80	45	20	122	55	140	63	110	50	128	58	94	42	107	48
4	100	46	21	179	81	215	97	159	72	195	88	98	44	120	54
6	150	74	34	291	130	349	158	261	118	319	145	161	71	191	86
8	200	177	80	579	263	661	300	539	244	607	275	361	164	407	185
10	250	177	80	784	356	880	399	732	332	822	373	458	208	516	234

Model 375ASTW1 with NRS option

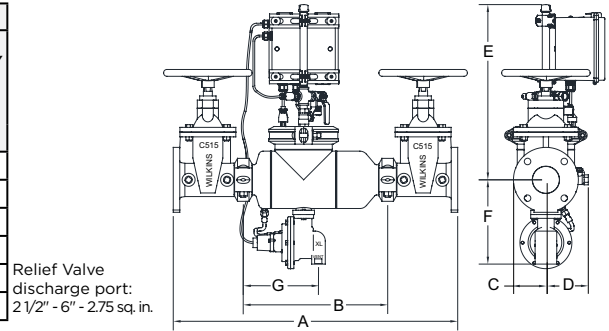

MODEL 375ASTW1	DIMENSION (approximate)																						
	A		A WITH BUTTERFLY VALVES		B LESS GATE VALVES		C		D		E NRS GATE		E OS&Y OPEN		E OS&Y CLOSED		E WITH BUTTERFLY VALVES		F		G		
in.	mm	in.	mm	in.	mm	in.	mm	in.	mm	in.	mm	in.	mm	in.	mm	in.	mm	in.	mm	in.	mm	in.	mm
2 1/2	65	31 7/8	810	28 3/4	730	16 5/8	422	4 1/2	216	8 1/2	184	26 1/8	663	26 1/8	663	26 1/8	663	26 1/8	663	9 3/4	248	8 5/8	219
3	80	32 7/8	835	29 3/8	746	16 5/8	422	4 1/2	216	8 1/2	184	26 5/16	668	26 5/16	668	26 5/16	668	26 5/16	668	9 3/4	248	8 5/8	219
4	100	34 7/8	886	30 1/4	768	16 5/8	422	4 1/2	216	8 1/2	203	26 1/2	673	26 1/2	673	26 1/2	673	26 1/2	673	9 3/4	248	8 5/8	219
6	150	43 1/2	1105	36 1/2	927	22 1/4	565	5 1/2	140	10	254	30 1/2	730	30 1/2	730	30 1/2	730	30 1/2	730	10 3/4	273	11 1/4	286
8	200	52 3/4	1340	45 3/4	1162	29 1/2	749	9 1/4	235	11	279	34 1/2	876	37	940	34 1/2	876	34 1/2	876	15 5/8	397	13 1/4	337
10	250	55 3/4	1416	49 3/4	1264	29 1/2	749	9 1/4	235	12	305	34 1/2	876	45 5/8	1159	34 3/4	883	34 1/2	876	15 5/8	397	13 1/2	343

Typical Installation

Local codes shall govern installation requirements. Unless otherwise specified, the assembly shall be mounted at a minimum of 12" (305mm) and a maximum of 30" (762mm) above adequate drains with sufficient side clearance for testing and maintenance. The installation shall be made so that no part of the unit can be submerged.

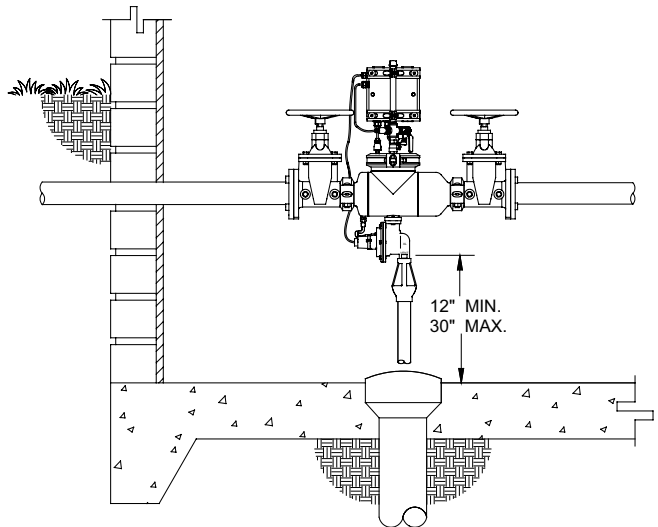

Detailed Specifications

The Reduced Pressure Principle Backflow Prevention Assembly shall be certified to NSF/ANSI/CAN 61, ASSE® Listed 1013, and supplied with full port gate valves. The main body and access cover shall be 304L Stainless Steel, the seat ring and check valve shall be NORYL™, the stem shall be stainless steel (ASTM A 276) and the seat disc elastomers shall be EPDM. The checks and the relief valve shall be accessible for maintenance without removing the device from the line. The Reduced Pressure Principle Backflow Prevention Assembly shall be a ZURN WILKINS Model 375ASTW1.