

MODEL SF-5100 & SF-5110 STAINLESS STEEL WALL MOUNTED FOUNTAIN

Lustrous satin-finish stainless steel satisfies the criteria for cleanliness and easy care in medical centers and office buildings. Push button control located on front panel. Vandal resistant bottom plate and mounting plate are standard. Beveled front with or without back plate.

-FP are frost proof models. It is recommended that a dual check valve backflow prevention be installed in the waterline going to any FP fountain.

Model SF-5100 fountain comes with a back plate.
Model SF-5110 fountain comes without a back plate.

**SF-5100**

FEATURES

- 18 gauge 304 stainless steel with brushed finish
- Stainless steel receptor with a vandal resistant chrome plated brass drain plug
- Vandal resistant access plates for security and simple future maintenance
- Simple flow adjustment without requiring the dismantling of the fountain
- All flow paths are lead-free with reinforced stainless-steel tubing that complies with NSF/ANSI/CAN 61: Q≤1 (AB100) standards
- In-line mesh screen Y strainer
- Protective stainless steel back plate
- ½” Inlet stop valve for simple future maintenance
- 1 ¼” IPS waste pipes included on each fountain

**SF-5110**

ORDERING OPTIONS

Part Number

SF-5100-



Optional

BFCA-1: Cane Touch Apron

SF-5100-FP-



Optional

BFCA-1: Cane Touch Apron

SF-5110-



Optional

BFCA-1: Cane Touch Apron

SF-5110-FP-



Optional

BFCA-1: Cane Touch Apron

DIMENSIONS

All dimensions subject to manufacturing variance of plus or minus 1/4" (6 mm)

SF-5100 9-5/8"H x 19"W with 13" extension

SF-5110 7"H x 12"W with 12-1/2" extension

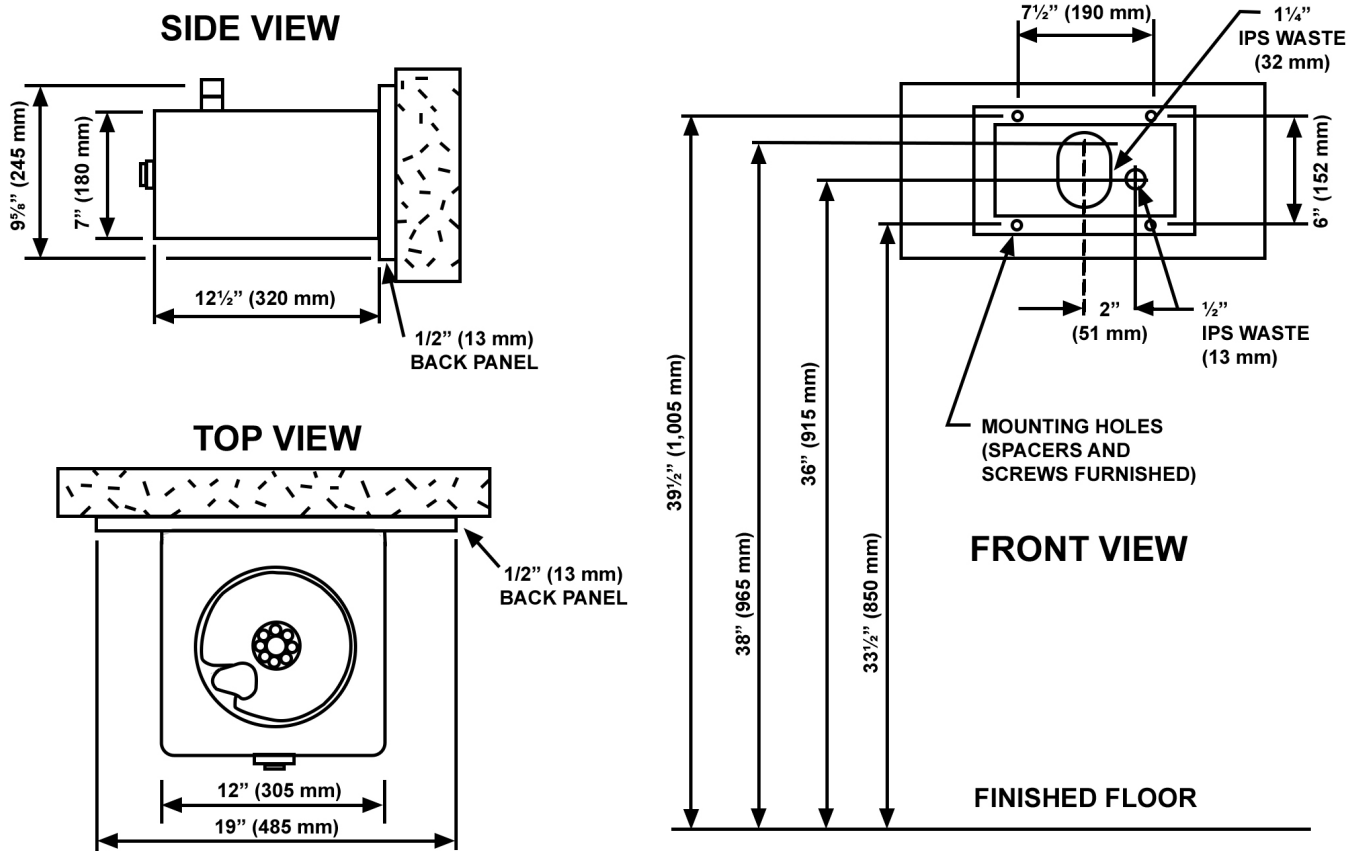

SF-5110

